

# VAL-MB-T2 1500DC-PV/2+V - Type 2 surge arrester



2905647

<https://www.phoenixcontact.com/ae/products/2905647>

Please be informed that the data shown in this PDF document is generated from our online catalog. Please find the complete data in the user documentation. Our general terms of use for downloads are valid.



Surge protective device for 2-pos. isolated and grounded 1,500 V DC PV voltage systems, for DIN rail mounting, temperature-monitored protective elements, status message on the module.

## Your advantages

- Space-saving installation, thanks to the compact design
- Double terminal block for safe and easy equipotential bonding connection
- Screw shafts with raised domes to ensure safe working
- Main connections with extended insertion funnels for increased resistance to creepage
- Visual display for checking the status directly on the device

## Commercial data

Item number	2905647
Packing unit	1 pc
Minimum order quantity	1 pc
Sales key	CL1
Product key	CL1341
Catalog page	Page 72 (C-4-2019)
GTIN	4046356984225
Weight per piece (including packing)	383.6 g
Weight per piece (excluding packing)	383.6 g
Customs tariff number	85354000
Country of origin	DE

# VAL-MB-T2 1500DC-PV/2+V - Type 2 surge arrester



2905647

<https://www.phoenixcontact.com/ae/products/2905647>

## Technical data

### Notes

#### General

Note	The product is also suitable for use in photovoltaic systems with max. short-circuit current $I_{SCPV} = 15 \text{ kA}$ (in accordance with EN 50539-11: 2013).
------	---

### Product properties

IEC test classification	PV II PV T2
EN type	T2
IEC power supply system	DC
Type	DIN rail module, one-piece
Product type	PV arrester
Product family	VALVETRAB MB
Installation location	Interior
Installation location of the disconnect device	Internal
Accessibility	Accessible
Connection configuration	Y configuration
SPD failure behavior	OCFM (Open-Circuit Failure Mode)
Surge protection fault message	optical

#### Insulation characteristics

Pollution degree	2
------------------	---

### Connection data

Connection method	Screw connection
Screw thread	M5
Tightening torque	3 Nm
Stripping length	16 mm
Conductor cross section flexible	2.5 mm <sup>2</sup> ... 35 mm <sup>2</sup>
Conductor cross section AWG	14 ... 2

### Dimensions

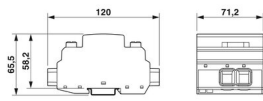
Dimensional drawing	
Width	71.2 mm
Height	120 mm
Depth	65.5 mm (incl. DIN rail 7.5 mm)
Horizontal pitch	4 Div.

# VAL-MB-T2 1500DC-PV/2+V - Type 2 surge arrester



2905647

<https://www.phoenixcontact.com/ae/products/2905647>

## Material specifications

Flammability rating according to UL 94	V-0
Insulating material	PA 6.6
	PBT
Housing material	PA 6.6

## Mechanical properties

### Mechanical data

Open side panel	No
-----------------	----

## Protective circuit

Mode of protection	(L+) - (L-)
	(L+) - PE
	(L-) - PE
Direction of action	(L+)-PE & (L-)-PE & (L+)-(L-)
Rated load current $I_L$	50 A
Residual current $I_{PE}$	$\leq 55 \mu\text{A DC}$
	$\leq 430 \mu\text{A AC}$
Standby power consumption $P_C$	$\leq 85 \text{ mVA}$
Nominal discharge current $I_n$ (8/20) $\mu\text{s}$	20 kA
Maximum discharge current $I_{max}$ (8/20) $\mu\text{s}$	40 kA
Total discharge current $I_{total}$ (8/20) $\mu\text{s}$	40 kA
Voltage protection level $U_p$	$\leq 4.5 \text{ kV}$
Residual voltage $U_{res}$	$\leq 4.5 \text{ kV (at } I_n)$
	$\leq 3.3 \text{ kV (at } 3 \text{ kA)}$
	$\leq 3.6 \text{ kV (at } 6.25 \text{ kA)}$
	$\leq 3.8 \text{ kV (at } 10 \text{ kA)}$
	$\leq 4.2 \text{ kV (at } 15 \text{ kA)}$
	$\leq 5.4 \text{ kV (at } 40 \text{ kA)}$
Response time $t_A$	$\leq 25 \text{ ns}$

### PV protective circuit

Connection configuration	Y configuration
SPD failure behavior	OCFM (Open-Circuit Failure Mode)

### Protective circuit DC voltage side (DC)

Open circuit voltage $U_{OCSTC}$	$\leq 1250 \text{ V DC}$
Maximum discharge current $I_{max}$ (8/20) $\mu\text{s}$	40 kA
Response time $t_A$	$\leq 25 \text{ ns}$
Total discharge current $I_{total}$ (8/20) $\mu\text{s}$	40 kA
Insulation resistance $R_{iso}$	$> 5 \text{ G}\Omega$ (at 500 V DC)
Nominal discharge current $I_n$ (8/20) $\mu\text{s}$	20 kA
Rated load current $I_L$	50 A
Continuous operating current $I_{CPV}$	$< 55 \mu\text{A}$

# VAL-MB-T2 1500DC-PV/2+V - Type 2 surge arrester



2905647

<https://www.phoenixcontact.com/ae/products/2905647>

Maximum continuous operating voltage $U_{CPV}$	1500 V DC
Short-circuit current rating $I_{SCPV}$	2000 A
Residual voltage $U_{res}$	$\leq 4.5$ kV (at $I_n$ )
	$\leq 3.3$ kV (at 3 kA)
	$\leq 3.6$ kV (at 6.25 kA)
	$\leq 3.8$ kV (at 10 kA)
	$\leq 4.2$ kV (at 15 kA)
	$\leq 5.4$ kV (at 40 kA)
Residual current $I_{PE}$	$\leq 55$ $\mu$ A DC
	$\leq 430$ $\mu$ A AC
Voltage protection level $U_p$	$\leq 4.5$ kV
Standby power consumption $P_C$	$\leq 85$ mVA

## Environmental and real-life conditions

### Ambient conditions

Degree of protection	IP20 (only when all terminal points are used)
Ambient temperature (operation)	-40 °C ... 80 °C
Ambient temperature (storage/transport)	-40 °C ... 80 °C
Altitude	$\leq 6000$ m (amsl)
Permissible humidity (operation)	5 % ... 95 %
Shock (operation)	50g (Half-sine / 11 ms / 3x $\pm$ X, $\pm$ Y, $\pm$ Z)
Vibration (operation)	5g (5 - 500 Hz/2.5 h/X, Y, Z)

## Standards and regulations

Standards/specifications	EN 61643-31
Note	2019
Standards/specifications	IEC 61643-31
Note	2018

## Mounting

Mounting type	DIN rail: 35 mm
---------------	-----------------

# VAL-MB-T2 1500DC-PV/2+V - Type 2 surge arrester

2905647

<https://www.phoenixcontact.com/ae/products/2905647>



## Drawings

Circuit diagram

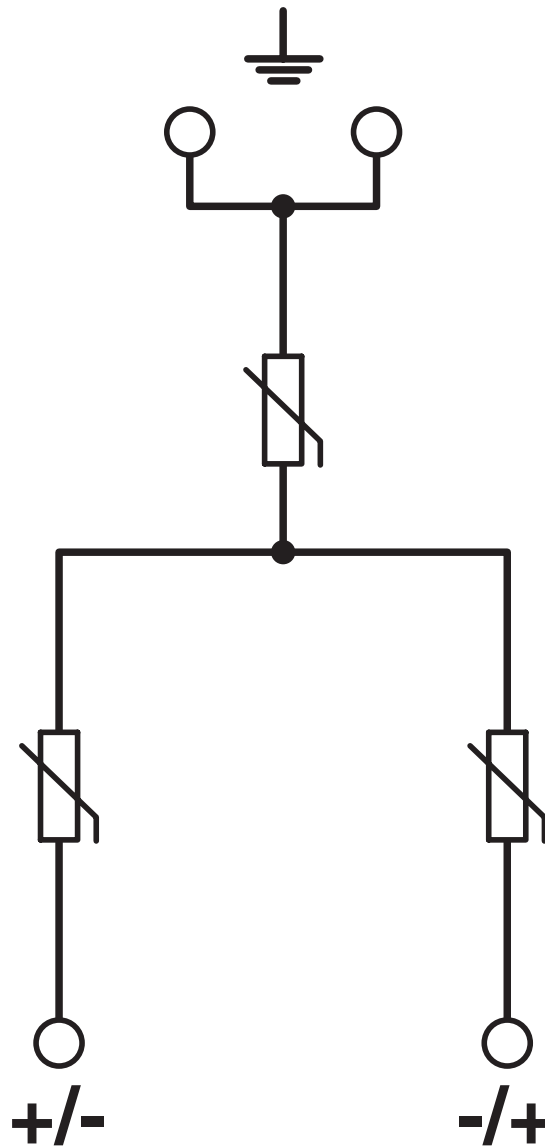

# VAL-MB-T2 1500DC-PV/2+V - Type 2 surge arrester



2905647

<https://www.phoenixcontact.com/ae/products/2905647>

Dimensional drawing

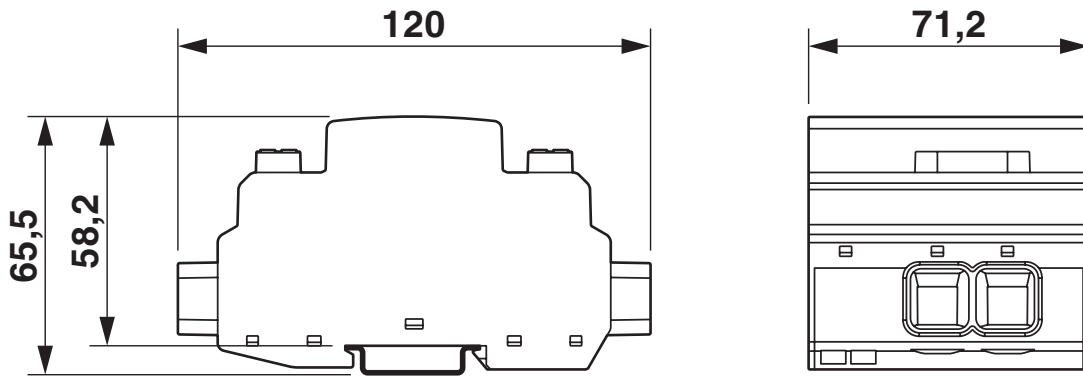

# VAL-MB-T2 1500DC-PV/2+V - Type 2 surge arrester



2905647

<https://www.phoenixcontact.com/ae/products/2905647>

## Approvals

To download certificates, visit the product detail page: <https://www.phoenixcontact.com/ae/products/2905647>



**IECEE CB Scheme**

Approval ID: NL-81007

**CCA**

Approval ID: NTR-NL 7938



**KEMA-KEUR**

Approval ID: 71-127691

# VAL-MB-T2 1500DC-PV/2+V - Type 2 surge arrester



2905647

<https://www.phoenixcontact.com/ae/products/2905647>

## Classifications

### ECLASS

ECLASS-11.0	27130805
ECLASS-13.0	27171402

### ETIM

ETIM 9.0	EC000941
----------	----------

### UNSPSC

UNSPSC 21.0	39121600
-------------	----------



# VAL-MB-T2 1500DC-PV/2+V - Type 2 surge arrester



2905647

<https://www.phoenixcontact.com/ae/products/2905647>

## Environmental product compliance

China RoHS	Environmentally friendly use period: unlimited = EFUP-e
	No hazardous substances above threshold values

# VAL-MB-T2 1500DC-PV/2+V - Type 2 surge arrester



2905647

<https://www.phoenixcontact.com/ae/products/2905647>

## Accessories

### ATP-QTTCB - Partition plate

3206238

<https://www.phoenixcontact.com/ae/products/3206238>

Partition plate, width: 2 mm, height: 102 mm, color: gray



---

### X-PEN 0,35 - Marker pen

0811228

<https://www.phoenixcontact.com/ae/products/0811228>

Marker pen without ink cartridge, for manual labeling of markers, labeling extremely wipe-proof, line thickness 0.35 mm



# VAL-MB-T2 1500DC-PV/2+V - Type 2 surge arrester



2905647

<https://www.phoenixcontact.com/ae/products/2905647>

## SZK PZ2 VDE - Screwdriver

1206463

<https://www.phoenixcontact.com/ae/products/1206463>



Screwdriver, PZ crosshead, VDE insulated, size: PZ 2 x 100 mm, 2-component grip, with non-slip grip

---

## SZS 0,4X2,5 VDE - Screwdriver

1205037

<https://www.phoenixcontact.com/ae/products/1205037>



Screwdriver, slot-headed, VDE insulated, size: 0.4 x 2.5 x 80 mm, 2-component grip, with non-slip grip

---

Phoenix Contact 2023 © - all rights reserved  
<https://www.phoenixcontact.com>

PHOENIX CONTACT Middle East FZ LLC  
1201N-1206N, Dubai Science Park Towers – North  
P.O. Box 345002, Dubai, United Arab Emirates  
(+971) 4 437-0324  
[info-me@phoenixcontact.com](mailto:info-me@phoenixcontact.com)