

# PSR-ESS-M0-H220-2001-C - Emergency stop switch



1221739

<https://www.phoenixcontact.com/mx/products/1221739>

Please be informed that the data shown in this PDF document is generated from our online catalog. Please find the complete data in the user documentation. Our general terms of use for downloads are valid.



Emergency stop switch, in conjunction with appropriate evaluation unit suitable for use up to PL e (EN ISO 13849-1), SIL 3 (EN IEC 62061), lighting to indicate the ready state, panel installation, spade connection

## Product description

Phoenix Contact emergency stop switches are electromechanical switching devices with a safety function. They are used to safely shut down or stop machines and systems in order to prevent or minimize personal injury and property damage. The portfolio includes a modular system as well as a preconfigured solution. The preconfigured emergency stop switch is ready for immediate use and is connected via a spade connector. Thanks to its compact design, the emergency stop switch can be used flexibly and can be installed in a wide range of control points. If necessary, the emergency stop switch can be disabled for machines or system parts that are switched off and are not ready.

## Your advantages

- Flexible use, thanks to compact design
- Easy connection with spade connector
- Rapid on-site diagnostics with color-coded switching position indicator
- In applications with appropriate evaluation device suitable for use up to PL e (EN ISO 13849-1), SIL 3 (EN IEC 62061)
- Increased occupational safety with illuminated active/inactive status indicator

## Commercial data

Item number	1221739
Packing unit	1 pc
Minimum order quantity	1 pc
Sales key	02
Product key	DNA621
GTIN	4063151310448
Weight per piece (including packing)	45.5 g
Weight per piece (excluding packing)	43.2 g
Customs tariff number	85365080
Country of origin	DE

# PSR-ESS-M0-H220-2001-C - Emergency stop switch



1221739

<https://www.phoenixcontact.com/mx/products/1221739>

## Technical data

### Product properties

Product type	Emergency stop switch
--------------	-----------------------

### Insulation characteristics

Overvoltage category	II
Pollution degree	2

### Electrical properties

Rated surge voltage	2.5 kV
---------------------	--------

### Dimensions

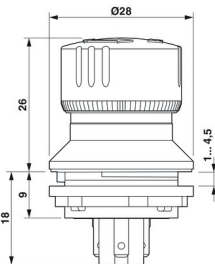
Dimensional drawing	
Depth	44 mm
Diameter	28 mm

### Material specifications

Flammability rating according to UL 94	V2 (Actuator)
	V0 (Contact element)
Housing material	PA/PC

### Environmental and real-life conditions

#### Ambient conditions

Degree of protection	IP65/IP67 (with professional installation in the appropriate installation space)
Ambient temperature (operation)	-25 °C ... 70 °C
Ambient temperature (storage/transport)	-40 °C ... 80 °C
Maximum altitude	max. 2000 m (Above sea level)
Shock	15g / 11 ms, in accordance with IEC 60068-2-27
Vibration (operation)	10 Hz ... 500 Hz, 0.35 mm amplitude, 5g, in accordance with IEC 60068-2-6

### Mounting

Mounting type	Panel mount
Assembly instructions	Mounting nut torque: 1.3 Nm ... 1.9 Nm
Mounting position	any

# PSR-ESS-M0-H220-2001-C - Emergency stop switch



1221739

<https://www.phoenixcontact.com/mx/products/1221739>

Connection method	Spade connection
-------------------	------------------

# PSR-ESS-M0-H220-2001-C - Emergency stop switch

1221739

<https://www.phoenixcontact.com/mx/products/1221739>



## Drawings

Dimensional drawing

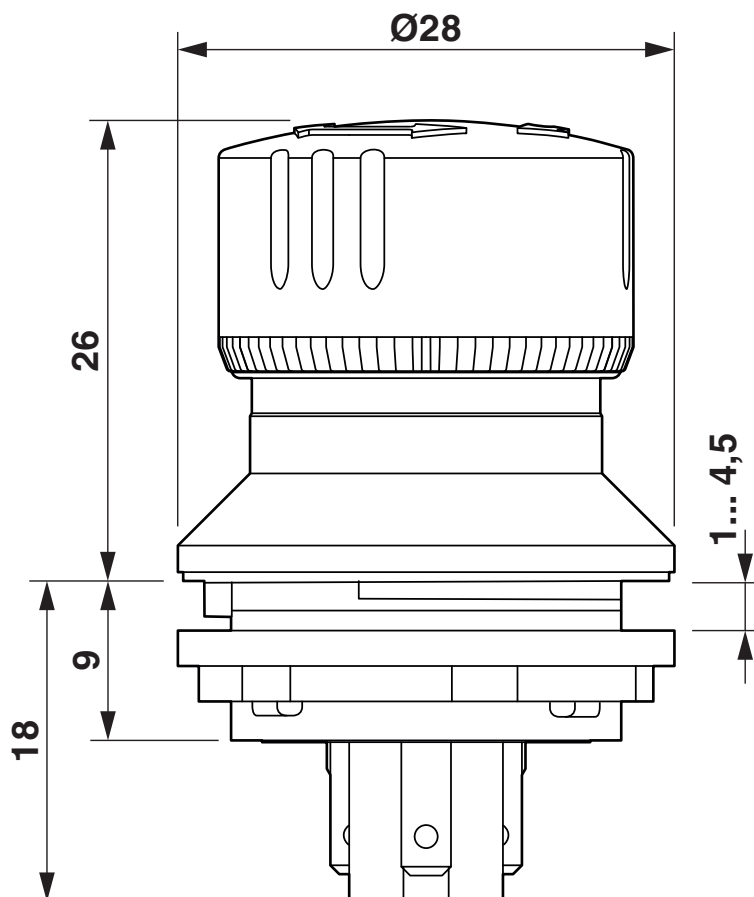

Dimensions (in mm)

1221739

<https://www.phoenixcontact.com/mx/products/1221739>

## Approvals

To download certificates, visit the product detail page: <https://www.phoenixcontact.com/mx/products/1221739>



**cUL Recognized**

Approval ID: FILE E 519465



**UL Recognized**

Approval ID: FILE E 519465

**Functional Safety**

Approval ID: B 029429 0031



**EAC**

Approval ID: RU\*DE\*B\*00073/21

**cULus Recognized**

# PSR-ESS-M0-H220-2001-C - Emergency stop switch



1221739

<https://www.phoenixcontact.com/mx/products/1221739>

## Classifications

### ECLASS

ECLASS-11.0	27371216
ECLASS-13.0	27371216
ECLASS-12.0	27371216

### ETIM

ETIM 9.0	EC000225
----------	----------

### UNSPSC

UNSPSC 21.0	39122200
-------------	----------

# PSR-ESS-M0-H220-2001-C - Emergency stop switch



1221739

<https://www.phoenixcontact.com/mx/products/1221739>

## Environmental product compliance

China RoHS	Environmentally friendly use period: unlimited = EFUP-e
	No hazardous substances above threshold values

# PSR-ESS-M0-H220-2001-C - Emergency stop switch



1221739

<https://www.phoenixcontact.com/mx/products/1221739>

## Accessories

### C-SCF 1/2,8X0,8 - Connector

3240153

<https://www.phoenixcontact.com/mx/products/3240153>



Slip-on sleeve, non-insulated, 0.5 ... 1 mm<sup>2</sup>, 2.8 x 0.8

---

Phoenix Contact 2023 © - all rights reserved  
<https://www.phoenixcontact.com>

PHOENIX CONTACT S.A. de C.V.  
Lago Alberto No. 319 - Piso 9  
Colonia Granada, Delegación Miguel Hidalgo, México, Ciudad de México, C.P. 11520  
+52/55/1101-1380  
[ventas@phoenixcontact.com.mx](mailto:ventas@phoenixcontact.com.mx)