

Inductive Sensors
BES M30MG1-PSC40F-S04G
 Order Code: BES02YJ

BALLUFF

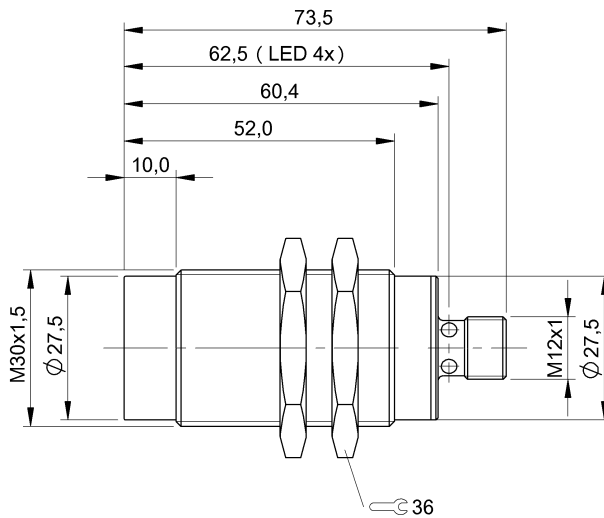

Basic features

Approval/Conformity	CE cULus WEEE
Basic standard	IEC 60947-5-2

Display/Operation

Function indicator	yes
Power indicator	no

Electrical connection

Connection	M12x1-Male, 4-pin, A-coded
Polarity reversal protected	yes
Protection against device mix-ups	yes
Short-circuit protection	yes

Electrical data

Load capacitance max. at Ue	1 µF
Min. operating current I _m	0 mA
No-load current I _o max., damped	10 mA
No-load current I _o max., undamped	10 mA
Operating voltage U _b	10...30 VDC
Output resistance R _a	47.0 kOhm
Rated insulation voltage U _i	75 V DC
Rated operating current I _e	200 mA
Rated operating voltage U _e DC	24 V
Rated short circuit current	100 A
Ready delay t _v max.	300 ms
Residual current I _r max.	100 µA
Ripple max. (% of U _e)	20 %
Switching frequency	100 Hz
Utilization category	DC -13
Voltage drop static max.	2 V

Environmental conditions

Ambient temperature	-25...70 °C
Contamination scale	3
EN 60068-2-27, Shock	Half-sinus, 30 g _n , 11 ms
EN 60068-2-6, Vibration	55 Hz, amplitude 1 mm, 3x30 min
IP rating	IP54

Functional safety

MTTF (40 °C)	380 a
--------------	-------

Interface

Switching output	PNP normally open (NO)
------------------	------------------------

Inductive Sensors
BES M30MG1-PSC40F-S04G
Order Code: BES02YJ



Material

Housing material	Brass, Chrome-plated
Material sensing surface	PBT

Mechanical data

Dimension	Ø 30 x 73.5 mm
Installation	non-flush
Size	M30x1.5
Tightening torque	70 Nm

Range/Distance

Assured operating distance Sa	32 mm
Hysteresis H max. (% of Sr)	10.0 %
Rated operating distance Sn	40 mm
Real switching distance sr	40 mm
Repeat accuracy max. (% of Sr)	5.0 %
Switching distance marking	■■■
Temperature drift max. (% of Sr)	10 %
Tolerance Sr	±10 %

Remarks

The sensor is functional again after the overload has been eliminated.
 EMC: For operating conditions with noise sources
 External protection circuit is required. Document 825345.
 For more information about MTTF and B10d see MTTF / B10d Certificate

Indication of the MTTF- / B10d value does not represent a binding composition and/or life expectancy assurance; these are simply experiential values with no warranty implications. These declared values also do not extend the expiration period for defect claims or affect it in any way.

Connector Drawings



Wiring Diagrams

