

2910132

<https://www.phoenixcontact.com/pc/products/2910132>

Please be informed that the data shown in this PDF document is generated from our Online Catalog. Please find the complete data in the user documentation. Our General Terms of Use for Downloads are valid.



Primary-switched DC/DC converter, QUINT POWER, DIN rail mounting, SFB Technology (Selective Fuse Breaking),- 24 V DC, output: 24 V DC / 5 A

## Product Description

QUINT DC/DC converter with maximum functionality

DC/DC converters alter the voltage level, regenerate the voltage at the end of long cables or enable the creation of independent supply systems by means of electrical isolation.

QUINT DC/DC converters magnetically and therefore quickly trip circuit breakers with six times the nominal current, for selective and therefore cost-effective system protection. The high level of system availability is additionally ensured, thanks to preventive function monitoring, as it reports critical operating states before errors occur.

## Your advantages

- Most powerful output side: easy system expansion, reliable heavy load startup and miniature circuit breaker tripping
- Most comprehensive signaling: preventive function monitoring reports critical operating states before errors occur
- Protective coating and ATEX/IECEx approval

## Commercial Data

Item number	2910132
Packing unit	1 pc
Minimum order quantity	1 pc
Product Key	CMDI43
GTIN	4055626536699
Weight per Piece (including packing)	834.6 g
Weight per Piece (excluding packing)	834 g
Customs tariff number	85044083
Country of origin	TH

## Technical Data

### Input data

Nominal input voltage range	24 V DC
Input voltage range	24 V DC -25 % ... +40 %
Wide-range input	no
Electric strength, max.	35 V DC (60 s)
Inrush current	typ. 1 A
Inrush current integral ( $I^2t$ )	< 0.05 A <sup>2</sup> s
Inrush current limitation	1 A
Mains buffering time	typ. 14 ms (24 V DC)
Current consumption	6.9 A (24 V DC)
Typical response time	300 ms (from SLEEP MODE)
Switch-on time	< 1 s
Input fuse	15 A (slow-blow, internal)
Recommended breaker for input protection	10 A ... 16 A (Characteristic B, C, D, K or comparable)

### Signal Remote (configurable)

Connection labeling	3.3 +
Function	Output power ON/OFF (remote)
Default	Output power ON (>40 k $\Omega$ /24 V DC/open bridge between REM and SGnd)

### Output data

Efficiency	typ. 92.2 % (24 V DC)
Output characteristic	U/I Advanced
	Smart HICCUP
	FUSE MODE
Nominal output voltage	24 V DC
Setting range of the output voltage ( $U_{Set}$ )	24 V DC ... 28 V DC (> 24 V DC, constant capacity)
Nominal output current ( $I_N$ )	5 A
Static Boost ( $I_{Stat.Boost}$ )	6.25 A
Dynamic Boost ( $I_{Dyn.Boost}$ )	10 A (5 s)
Selective Fuse Breaking ( $I_{SFB}$ )	30 A (15 ms)
Magnetic circuit breaker tripping	A1 ... A4 / B2 / C1 ... C2 / Z1 ... Z4
Short-circuit-proof	yes
No-load proof	yes
Output power ( $P_N$ )	120 W
Output power ( $P_{Stat.Boost}$ )	150 W
Output power ( $P_{Dyn.Boost}$ )	240 W (5 s)
Feedback voltage resistance	$\leq$ 35 V DC
Protection against overvoltage at the output (OVP)	$\leq$ 30 V DC
Residual ripple	< 10 mV <sub>PP</sub>
Control deviation	< 1 % (change in load, static 10 % ... 90 %)

2910132

<https://www.phoenixcontact.com/pc/products/2910132>

Control deviation	< 1 % (change in load, static 10 % ... 90 %)
Control deviation	< 1 % (change in load, static 10 % ... 90 %)
Rise time	< 1 s ( $U_{OUT}$ (10 % ... 90 %))
Connection in series	yes
Maximum no-load power dissipation	< 2 W
Power loss nominal load max.	< 10 W
Power dissipation SLEEP MODE	< 1 W
Connection in parallel	yes, for redundancy and increased capacity

### Signal Out 1 (configurable)

Connection labeling	3.5 +
Digital	0 V DC
	24 V DC
	20 mA
Signal option	Output voltage
	Output current
	Output power
	Operating hours
	Early warning of high temperatures
	OVP voltage limitation active
Default	$U_{IN}$ input voltage OK

### Signal Out 2 (configurable)

Connection labeling	3.6 +
Digital	0 V DC
	24 V DC
	20 mA
Default	Output power
Signal option	Output voltage
	Output current
	Operating hours
	Early warning of high temperatures
	OVP voltage limitation active
Analog	4 mA ... 20 mA $\pm 5$ % (Load $\leq 400 \Omega$ )
Signal option	Output voltage
	Output current
	Output power

### Signal relay 13/14 (configurable)

Connection labeling	3.1, 3.2
Switch contact (floating)	floating
Maximum contact load	24 V DC
	1 A
	30 V AC
	0.5 A

2910132

<https://www.phoenixcontact.com/pc/products/2910132>

Default	Output voltage
Signal option	Output current
	Output power
	Operating hours
	Early warning of high temperatures
	OVP voltage limitation active
	U <sub>IN</sub> input voltage OK

## Signal ground SGnd

Connection labeling	3.4 +
Function	Signal ground
Reference potential	to OUT1, OUT2, REM

## Connection data

### Input

Position	1.x
----------	-----

### Conductor connection

Connection method	Push-in connection
rigid	0.2 mm <sup>2</sup> ... 6 mm <sup>2</sup>
flexible	0.2 mm <sup>2</sup> ... 6 mm <sup>2</sup>
flexible with ferrule without plastic sleeve	0.2 mm <sup>2</sup> ... 4 mm <sup>2</sup>
flexible with ferrule with plastic sleeve	0.2 mm <sup>2</sup> ... 4 mm <sup>2</sup>
rigid (AWG)	24 ... 10
Stripping length	10 mm

### Output

Position	2.x
----------	-----

### Conductor connection

Connection method	Push-in connection
rigid	0.2 mm <sup>2</sup> ... 6 mm <sup>2</sup>
flexible	0.2 mm <sup>2</sup> ... 6 mm <sup>2</sup>
flexible with ferrule without plastic sleeve	0.2 mm <sup>2</sup> ... 4 mm <sup>2</sup>
flexible with ferrule with plastic sleeve	0.2 mm <sup>2</sup> ... 4 mm <sup>2</sup>
rigid (AWG)	24 ... 10
Stripping length	10 mm

### Signal

Position	3.x
----------	-----

### Conductor connection

Connection method	Push-in connection
rigid	0.2 mm <sup>2</sup> ... 1 mm <sup>2</sup>
flexible	0.2 mm <sup>2</sup> ... 1.5 mm <sup>2</sup>
flexible with ferrule without plastic sleeve	0.2 mm <sup>2</sup> ... 1.5 mm <sup>2</sup>

2910132

<https://www.phoenixcontact.com/pc/products/2910132>

flexible with ferrule with plastic sleeve	0.2 mm <sup>2</sup> ... 0.75 mm <sup>2</sup>
rigid (AWG)	24 ... 16
Stripping length	8 mm

## LED signaling

Types of signaling	LED
	Floating signal contact
	Active signal output Out1 (digital, configurable)
	Active signal output Out2 (analog, configurable)
	Remote contact
	Signal ground SGnd
Signal threshold	> 100 % (LED lights up yellow, output power > 120 W)
	> 75 % (LED lights up green, output power > 90 W)
	> 50 % (LED lights up green, output power > 60 W)
	> 0.9 x U <sub>Set</sub> (LED lights up green)
	< 0.9 x U <sub>Set</sub> (LED flashes green)
	> 0.8 x U <sub>InNom</sub> (LED off)
	< 0.8 x U <sub>InNom</sub> (LED lights up yellow)

## Electrical properties

Number of phases	1.00
Insulation voltage input/output	4 kV DC (type test)
	2 kV DC (routine test)
Switching frequency	190 kHz ... 220 kHz (Auxiliary converter stage)
	50 kHz ... 420 kHz (Main converter stage)

## Product properties

Product type	DC/DC converters
Product family	QUINT POWER
MTBF (IEC 61709, SN 29500)	> 1600000 h (25 °C)
	> 930000 h (40 °C)
	> 380000 h (60 °C)

## Insulation characteristics

Protection class	Special with SELV input and output
Degree of pollution	2

## Life expectancy (electrolytic capacitors)

Current	2.5 A
Temperature	40 °C
Time	422000 h
Additional text	24 V DC

## Life expectancy (electrolytic capacitors)

Current	5 A
Temperature	40 °C

2910132

<https://www.phoenixcontact.com/pc/products/2910132>

Time	260000 h
Additional text	24 V DC

## Life expectancy (electrolytic capacitors)

Current	5 A
Temperature	30 °C
Time	520000 h
Additional text	24 V DC

## Dimensions

Width	36 mm
Height	130 mm
Depth	125 mm

## Installation dimensions

Installation distance right/left (active)	15 mm / 15 mm ( $\leq 70$ °C)
Installation distance right/left (passive)	0 mm / 0 mm ( $\leq 70$ °C)
Installation distance top/bottom (active)	50 mm / 50 mm ( $\leq 70$ °C)
Installation distance top/bottom (passive)	50 mm / 50 mm ( $\leq 70$ °C)

## Alternative assembly

Width	122 mm
Height	130 mm
Depth	39 mm

## Mounting

Mounting type	DIN rail mounting
Assembly instructions	alignable: $P_N \geq 50\%$ , 5 mm horizontally, 15 mm next to active components, 50 mm vertically alignable: $P_N < 50\%$ , 0 mm horizontally, 40 mm vertically top, 20 mm vertically bottom
With protective coating	yes

## Material specifications

Flammability rating according to UL 94 (housing / terminal blocks)	V0
Housing material	Metal
Hood version	Stainless steel X6Cr17
Side element version	Aluminum

## Environmental and real-life conditions

## Ambient conditions

Degree of protection	IP20
Ambient temperature (operation)	-40 °C ... 70 °C (> 60 °C Derating: 2,5 %/K)
Ambient temperature (storage/transport)	-40 °C ... 85 °C
Maximum altitude	$\leq 5000$ m (> 2000 m, observe derating)
Climatic class	3K3 (EN 60721)

Max. permissible relative humidity (operation)	≤ 100 % (at 25 °C, non-condensing)
Shock	18 ms, 30g, in each space direction (according to IEC 60068-2-27)
Vibration (operation)	5 Hz ... 100 Hz resonance search 2.3g, 90 min., resonance frequency 2.3g, 90 min. (according to DNV GL Class C)

## Standards and regulations

### Overvoltage category

EN 61010-1	II
EN 62477-1	III

### Safety for measurement, control, and laboratory equipment

Standards/specifications	IEC 61010-1
--------------------------	-------------

### Protective extra-low voltage

Standards/specifications	EN 61010-1 (SELV)
	IEC 61010-2-201 (PELV)

### Explosive atmospheres

Standards/specifications	IEC 60079-0
	IEC 60079-7
	IEC 60079-11
	IEC 60079-15

### Mains voltage dips

Standards/specifications	EN 61000-4-29
--------------------------	---------------

## Approval data

### UL

Identification	UL Listed UL 61010-1
	<input type="checkbox"/> II 3 G Ex ec ic nC IIC T4 Gc

### UL

Identification	UL Listed UL 61010-2-201
	Ex ec ic nC IIC T4 Gc

### UL

Identification	UL ANSI/ISA-12.12.01 Class I, Division 2, Groups A, B, C, D T4 (Hazardous Location)
----------------	---

### CSA

Identification	CAN/CSA-C22.2 No. 61010-1-12
----------------	------------------------------

### CSA

Identification	CAN/CSA-IEC 61010-2-201:14
----------------	----------------------------

### SIQ

Identification	Type tested (type approved)
----------------	-----------------------------

2910132

<https://www.phoenixcontact.com/pc/products/2910132>

## SIQ

Identification	CB scheme (IEC 61010-1, IEC 61010-2-201)
----------------	--

## Shipbuilding

Identification	DNV GL
----------------	--------

## Shipbuilding

Identification	ABS
----------------	-----

## ATEX

Identification	SIQ 21 ATEX 024 X
	<input type="checkbox"/> II 3 G Ex ec ic nC IIC T4 Gc

## IECEX

Identification	IECEX SIQ 19.0003X
	Ex ec ic nC IIC T4 Gc

## EMC data

Low Voltage Directive	Conformance with Low Voltage Directive 2014/35/EC
Electromagnetic compatibility	Conformance with EMC Directive 2014/30/EU
EMC requirements for noise emission	EN 61000-6-3
	EN 61000-6-4
EMC requirements for noise immunity	EN 61000-6-1
	EN 61000-6-2
EMC requirements, power plant	IEC 61850-3
	EN 61000-6-5
Conducted noise emission	EN 55016
	EN 61000-6-3 (Class B)
Interference emission	Interference emission in accordance with EN 61000-6-3 (residential and commercial) and EN 61000-6-4 (industrial)
Noise emission	Additional basic standard EN 61000-6-5 (immunity in power station), IEC/EN 61850-3 (energy supply)
Noise emission	EN 55016
	EN 61000-6-3 (Class B)
Noise immunity	Immunity in accordance with EN 61000-6-1 (residential), EN 61000-6-2 (industrial), and EN 61000-6-5 (power station equipment zone), IEC/EN 61850-3 (power supply)
DNV GL conducted interference	Class B
Additional text	Bridge and deck area
DNV GL noise radiation	Class B
Additional text	Bridge and deck area

## Electrostatic discharge

Standards/regulations	EN 61000-4-2
-----------------------	--------------

## Electrostatic discharge

Contact discharge	8 kV (Test Level 4)
-------------------	---------------------



2910132

<https://www.phoenixcontact.com/pc/products/2910132>

Discharge in air	15 kV (Test Level 4)
Comments	Criterion A

#### Electromagnetic HF field

Standards/regulations	EN 61000-4-3
-----------------------	--------------

#### Electromagnetic HF field

Frequency range	80 MHz ... 1 GHz
Test field strength	20 V/m (Test Level 3)
Frequency range	1 GHz ... 6 GHz
Test field strength	10 V/m (Test Level 3)
Comments	Criterion A

#### Fast transients (burst)

Standards/regulations	EN 61000-4-4
-----------------------	--------------

#### Fast transients (burst)

Input	2 kV (Test Level 3 - asymmetrical)
Output	2 kV (Test Level 3 - asymmetrical)
Signal	2 kV (Test Level 4 - asymmetrical)
Comments	Criterion A

#### Surge voltage load (surge)

Standards/regulations	EN 61000-4-5
Input	1 kV (Test Level 3 - symmetrical)
	2 kV (Test Level 3 - asymmetrical)
Output	1 kV (Test Level 3 - symmetrical)
	2 kV (Test Level 3 - asymmetrical)
Signal	2 kV (Test Level 3 - asymmetrical)
Comments	Criterion A

#### Conducted interference

Standards/regulations	EN 61000-4-6
-----------------------	--------------

#### Conducted interference

I/O/S	asymmetrical
Frequency range	0.15 MHz ... 80 MHz
Comments	Criterion A
Voltage	10 V (Test Level 3)

#### Power frequency magnetic field

Standards/regulations	EN 61000-4-8
Frequency	16.7 Hz
	50 Hz
	60 Hz
Test field strength	100 A/m
Additional text	60 s
Comments	Criterion A

2910132

<https://www.phoenixcontact.com/pc/products/2910132>

Frequency	50 Hz
	60 Hz
Frequency range	50 Hz ... 60 Hz
Test field strength	1 kA/m
Additional text	3 s
Comments	Criterion A
Frequency	0 Hz
Test field strength	300 A/m
Additional text	DC, 60 s
Comments	Criterion A

## Voltage dips

Standards/regulations	EN 61000-4-29
Voltage	24 V DC
Voltage dip	70 %
Time	100 ms
Additional text	Test Level 2
Comments	Criterion A
Voltage dip	40 %
Time	100 ms
Additional text	Test Level 2
Comments	Criterion A
Voltage dip	0 %
Time	50 ms
Additional text	Test Level 2
Comments	Criterion B

## Pulse-shape magnetic field

Standards/regulations	EN 61000-4-9
Test field strength	1000 A/m
Comments	Criterion A

## Asymmetrical conducted disturbance variables

Standards/regulations	EN 61000-4-16
Test level 1	15 Hz 150 Hz (Test Level 3)
Voltage	10 V 1 V
Test level 2	150 Hz 1.5 kHz (Test Level 3)
Voltage	1 V
Test level 3	1.5 kHz 15 kHz (Test Level 3)
Voltage	1 V 10 V
Test level 4	15 kHz 150 kHz (Test Level 3)
Voltage	10 V
Test level 5	16.7 Hz 50 Hz 60 Hz 150 Hz 180 Hz (Test Level 3)
Voltage	10 V (Permanent)
Test level 6	0 Hz 16.7 Hz 50 Hz 60 Hz (Test Level 3)

2910132

<https://www.phoenixcontact.com/pc/products/2910132>

Voltage	100 V (1 s)
Comments	Criterion A

#### Alternating component of direct voltage

Standards/regulations	EN 61000-4-17
Alternating component	15 % ( $U_N$ )
Frequency	50 Hz
	100 Hz
	150 Hz
Comments	Criterion A
Alternating component	14 % ( $U_N$ )
Frequency	300 Hz
Comments	Criterion A

#### Attenuated oscillating wave

Standards/regulations	EN 61000-4-18
Input, output (test level 1)	100 kHz 1 MHz (Test Level 3 - symmetrical)
Voltage	1 kV
Input, output (test level 2)	100 kHz 1 MHz (Test Level 2 - asymmetrical)
Voltage	1 kV
Input, output (test level 3)	10 MHz (Test Level 2 - asymmetrical)
Voltage	0.5 kV
Signals (test level 1)	100 kHz 1 MHz (Test Level 2 - symmetrical)
Voltage	0.5 kV
Signals (test level 2)	100 kHz 1 MHz (Test Level 2 - asymmetrical)
Voltage	1 kV
Comments	Criterion A

#### Attenuated oscillating magnetic field

Standards/regulations	EN 61000-4-10
Test field strength	100 A/m
Test level 1	100 kHz
Test field strength	100 A/m
Test level 2	1 MHz
Comments	Criterion A

#### Criteria

Criterion A	Normal operating behavior within the specified limits.
Criterion B	Temporary impairment to operational behavior that is corrected by the device itself.
Criterion C	Temporary adverse effects on the operating behavior, which the device corrects automatically or which can be restored by actuating the operating elements.

2910132

<https://www.phoenixcontact.com/pc/products/2910132>

Drawings

Block diagram

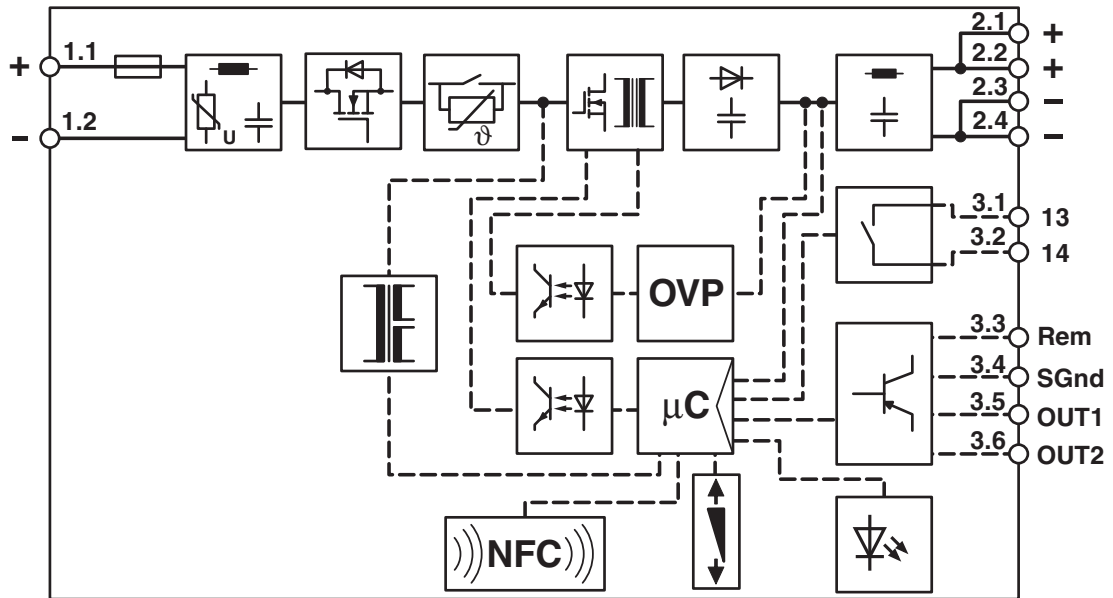

Schematic diagram

# Housing

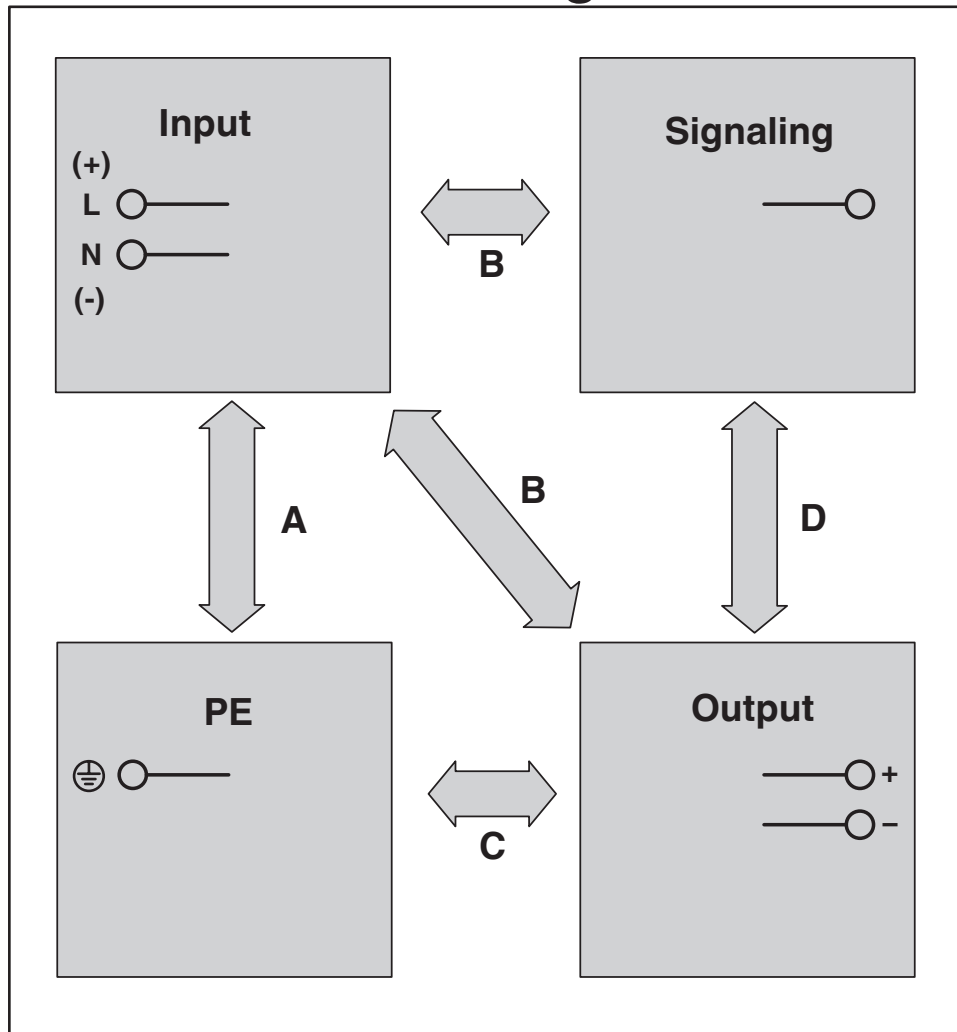

Diagram

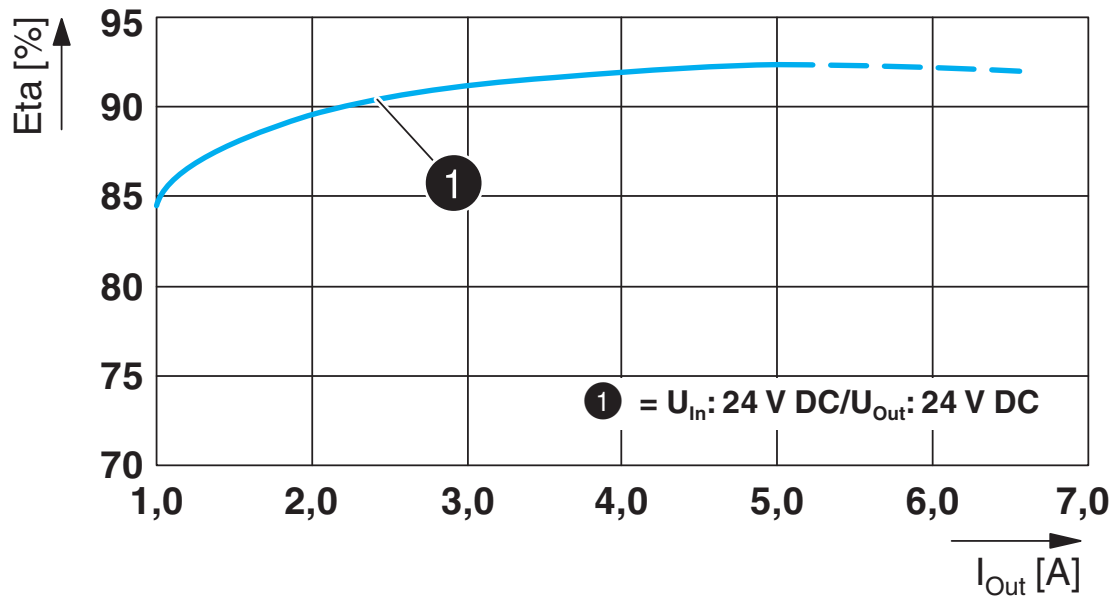

Diagram

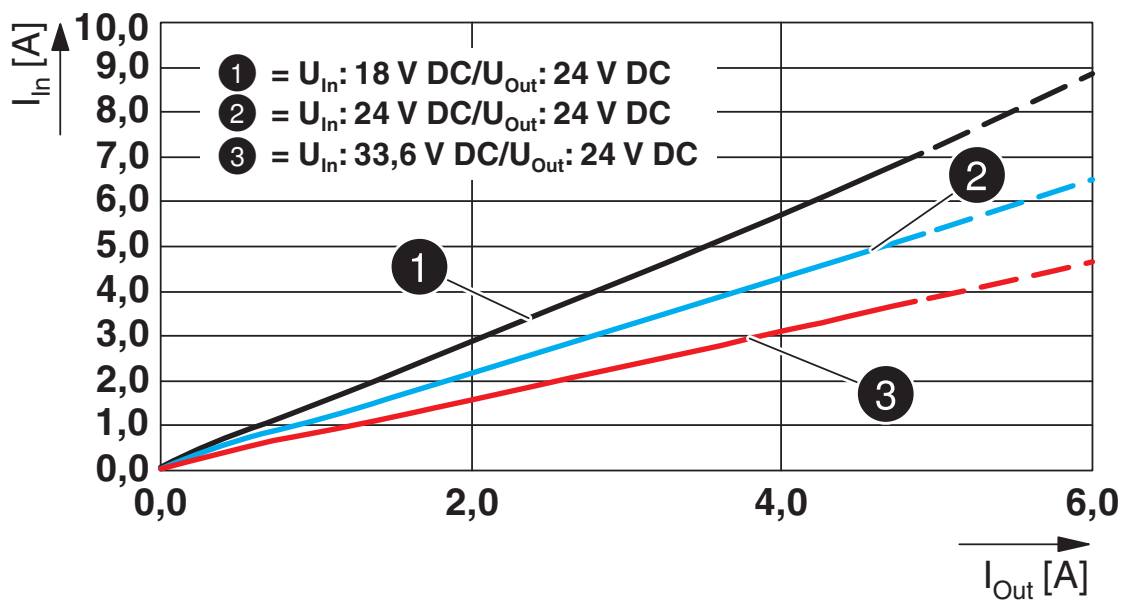

2910132

<https://www.phoenixcontact.com/pc/products/2910132>

## Approvals



**EAC**

Approval ID: RU S-DE.BL08.W.00764



**LR**

Approval ID: 17-20107-03



**NK**

Approval ID: TA21182M



**UL Listed**

Approval ID: FILE E 123528



**cUL Listed**

Approval ID: FILE E 123528



**BV**

Approval ID: 57060/A1 BV



**EAC**

Approval ID: RU S-DE.BL08.W.00764



**cUL Listed**

Approval ID: FILE E 123528



**UL Listed**

Approval ID: FILE E 123528



**NK**

Approval ID: TA21182M



**LR**

Approval ID: 17-20107-03

**DNV**

Approval ID: TAA00000BV

# DC/DC converters - QUINT4-PS/24DC/24DC/5/PT/CO



2910132

<https://www.phoenixcontact.com/pc/products/2910132>

## DNV

Approval ID: TAA00000BV



## IECEX

Approval ID: IECEX SIQ 19.0003X



## ATEX

Approval ID: SIQ 21 ATEX 024 X



## IECEX

Approval ID: IECEX SIQ 19.0003X



## ATEX

Approval ID: SIQ 21 ATEX 024 X



2910132

<https://www.phoenixcontact.com/pc/products/2910132>

## Classifications

### ECLASS

ECLASS-9.0	27210901
ECLASS-10.0.1	27210901
ECLASS-11.0	27040701

### ETIM

ETIM 8.0	EC002540
----------	----------

### UNSPSC

UNSPSC 21.0	39121000
-------------	----------

2910132

<https://www.phoenixcontact.com/pc/products/2910132>

## Environmental Product Compliance

REACH SVHC	Lead 7439-92-1
China RoHS	Environmentally Friendly Use Period = 25;
	For information on hazardous substances, refer to the manufacturer's declaration available under "Downloads"

2910132

<https://www.phoenixcontact.com/pc/products/2910132>

## Accessories

### Mounting adapter

Mounting adapter - UWA 182/52 - 2938235

<https://www.phoenixcontact.com/pc/products/2938235>



Universal wall adapter for securely mounting the device in the event of strong vibrations. The device is screwed directly onto the mounting surface. The universal wall adapter is attached on the top/bottom.

---

### Mounting adapter

Mounting adapter - UWA 130 - 2901664

<https://www.phoenixcontact.com/pc/products/2901664>



2-piece universal wall adapter for securely mounting the device in the event of strong vibrations. The profiles that are screwed onto the side of the device are screwed directly onto the mounting surface. The universal wall adapter is attached on the left/right.

2910132

<https://www.phoenixcontact.com/pc/products/2910132>

## Mounting adapter

Mounting adapter - QUINT-PS-ADAPTERS7/1 - 2938196

<https://www.phoenixcontact.com/pc/products/2938196>

Assembly adapter for QUINT-PS... power supply on S7-300 rail



---

## Programming adapter

Programming adapter - TWN4 MIFARE NFC USB ADAPTER - 2909681

<https://www.phoenixcontact.com/pc/products/2909681>

Near Field Communication (NFC) programming adapter with USB interface for the wireless configuration of NFC-capable products from Phoenix Contact with software. A separate USB driver is not required.



2910132

<https://www.phoenixcontact.com/pc/products/2910132>

## Electronic circuit breaker

Electronic circuit breaker - CBMC E4 24DC/1-4A NO - 2906031

<https://www.phoenixcontact.com/pc/products/2906031>



Multi-channel electronic circuit breaker for protecting four loads at 24 V DC in the event of overload and short circuit. With electronic locking of the set nominal currents. For installation on DIN rails.

---

## Electronic circuit breaker

Electronic circuit breaker - CBMC E4 24DC/1-10A NO - 2906032

<https://www.phoenixcontact.com/pc/products/2906032>



Multi-channel electronic circuit breaker for protecting four loads at 24 V DC in the event of overload and short circuit. With electronic locking of the set nominal currents. For installation on DIN rails.

2910132

<https://www.phoenixcontact.com/pc/products/2910132>

## Electronic circuit breaker

Electronic circuit breaker - CBMC E4 24DC/1-4A+ IOL - 2910410

<https://www.phoenixcontact.com/pc/products/2910410>



Multi-channel electronic circuit breaker with IO-Link interface for protecting four loads at 24 V DC in the event of overload and short circuit. With electronic locking of the set nominal currents. For installation on DIN rails.

---

## Electronic circuit breaker

Electronic circuit breaker - CBMC E4 24DC/1-10A IOL - 2910411

<https://www.phoenixcontact.com/pc/products/2910411>



Multi-channel electronic circuit breaker with IO-Link interface for protecting four loads at 24 V DC in the event of overload and short circuit. With electronic locking of the set nominal currents. For installation on DIN rails.

2910132

<https://www.phoenixcontact.com/pc/products/2910132>

## Electronic circuit breaker

Electronic circuit breaker - CBM E4 24DC/0.5-10A NO-R - 2905743

<https://www.phoenixcontact.com/pc/products/2905743>



Multi-channel, electronic circuit breaker with active current limitation for protecting four loads at 24 V DC in the event of overload and short circuit. With nominal current assistant and electronic locking of the set nominal currents. For installation on DIN rails.

---

## Electronic circuit breaker

Electronic circuit breaker - CBM E8 24DC/0.5-10A NO-R - 2905744

<https://www.phoenixcontact.com/pc/products/2905744>



Multi-channel, electronic circuit breaker with active current limitation for protecting eight loads at 24 V DC in the event of overload and short circuit. With nominal current assistant and electronic locking of the set nominal currents. For installation on DIN rails.

---

Phoenix Contact 2023 © - all rights reserved  
<https://www.phoenixcontact.com>

PHOENIX CONTACT GmbH & Co. KG  
Flachsmarktstraße 8  
D-32825 Blomberg  
+49 (0) 5235-3 00  
[info@phoenixcontact.com](mailto:info@phoenixcontact.com)