

# Redundancy module - TRIO2-DIODE/12-24DC/2X10/1X20



2907380

<https://www.phoenixcontact.com/pc/products/2907380>

Please be informed that the data shown in this PDF document is generated from our Online Catalog. Please find the complete data in the user documentation. Our General Terms of Use for Downloads are valid.

Redundancy module, 12 V - 24 V DC, 2 x 10 A, 1 x 20 A



## Product Description

A safe redundant system is the result of the parallel connection of two power supply units which are decoupled from one another. To further increase system availability, TRIO DIODE provides the solution: decoupling with diode.

## Your advantages

- Quick and easy installation with Push-in connection technology
- Save energy
- Redundant wiring up to the load
- Permanent monitoring of redundancy
- Consistent redundancy up to the load

## Commercial Data

Item number	2907380
Packing unit	1 pc
Minimum order quantity	1 pc
Product Key	CMRO43
Catalog Page	Page 308 (C-4-2019)
GTIN	4055626198262
Weight per Piece (including packing)	395.5 g
Weight per Piece (excluding packing)	395.5 g
Customs tariff number	85049090
Country of origin	CN

# Redundancy module - TRIO2-DIODE/12-24DC/2X10/1X20



2907380

<https://www.phoenixcontact.com/pc/products/2907380>

## Technical Data

### Input data

#### DC operation

Nominal input voltage range	12 V DC ... 24 V DC
Input voltage range	10 V DC ... 30 V DC
Voltage type of supply voltage	DC
Reverse polarity protection	< Yes60 V
Nominal input current ( $I_N$ )	2x 10 A (-25 °C ... 60 °C) 1x 20 A (-25 °C ... 60 °C)
Maximum current $I_{max}$	2x 15 A (-25°C ... 40°C) 1x 30 A (-25°C ... 40°C)
Nominal input current ( $I_N$ )	2x 10 A (-25 °C ... 60 °C) 1x 20 A (-25 °C ... 60 °C)
Transient surge protection	Varistor
Voltage drop, input/output	0.5 V

### Output data

Efficiency	> 97 %
Output voltage	$U_{in}$ -
Nominal output current ( $I_N$ )	20 A 10 A
Derating	60 °C ... 70 °C (2.5%/K)
Power loss nominal load max.	5 W ( $I_{OUT} = 10$ A)
Connection in series	No
Derating	60 °C ... 70 °C (2.5%/K)

### Connection data

#### Input

Connection method	Push-in connection
Conductor cross section solid min.	0.2 mm <sup>2</sup>
Conductor cross section solid max.	4 mm <sup>2</sup>
Conductor cross section flexible min.	0.2 mm <sup>2</sup>
Conductor cross section flexible max.	2.5 mm <sup>2</sup>
Conductor cross section AWG min.	16
Conductor cross section AWG max.	12
Stripping length	10 mm

#### Output

Connection method	Screw connection
Conductor cross section solid min.	0.2 mm <sup>2</sup>
Conductor cross section solid max.	10 mm <sup>2</sup>
Conductor cross section flexible min.	0.2 mm <sup>2</sup>

# Redundancy module - TRIO2-DIODE/12-24DC/2X10/1X20



2907380

<https://www.phoenixcontact.com/pc/products/2907380>

Conductor cross section flexible max.	6 mm <sup>2</sup>
Conductor cross section AWG min.	12
Conductor cross section AWG max.	8
Stripping length	15 mm
Screw thread	M3
Tightening torque, min	0.5 Nm
Tightening torque max	0.6 Nm

## Electrical properties

Insulation voltage input, output / housing	500 V
--	-------

## Product properties

Product type	Redundancy module
Product family	TRIO DIODE
MTBF (IEC 61709, SN 29500)	66425178 h (25 °C)
	56586762 h (40 °C)
	41744164 h (60 °C)

## Insulation characteristics

Protection class	III
Degree of pollution	2

## Dimensions

Width	35 mm
Height	130 mm
Depth	115 mm

## Installation dimensions

Installation distance right/left	0 mm / 0 mm
Installation distance top/bottom	50 mm / 50 mm

## Mounting

Mounting type	DIN rail mounting
Assembly instructions	alignable: horizontally 0 mm, vertically 50 mm
Mounting position	horizontal DIN rail NS 35, EN 60715

## Material specifications

Flammability rating according to UL 94 (housing / terminal blocks)	V0
Housing material	Metal
Type of housing	Steel sheet, zinc-plated
Side element version	Aluminum

## Environmental and real-life conditions

### Ambient conditions

# Redundancy module - TRIO2-DIODE/12-24DC/2X10/1X20



2907380

<https://www.phoenixcontact.com/pc/products/2907380>

Degree of protection	IP20
Ambient temperature (operation)	-25 °C ... 70 °C (> 60 °C Derating: 2,5 %/K)
Ambient temperature (storage/transport)	-40 °C ... 85 °C
Climatic class	3K3 (in acc. with EN 60721)
Max. permissible relative humidity (operation)	≤ 95 % (at 25 °C, non-condensing)
Shock	18 ms, 30g, in each space direction (according to IEC 60068-2-27)
Vibration (operation)	< 15 Hz, amplitude ±2.5 mm (according to IEC 60068-2-6) 15 Hz ... 150 Hz, 2.3g, 90 min.

## Standards and regulations

Standard – Electronic equipment for use in electrical power installations and their assembly into electrical power installations	EN 50178/VDE 0160 (PELV)
Standard - Electrical safety	IEC 62368-1 (SELV)
Standard – Safety extra-low voltage	IEC 62368-1 (SELV) und EN 60204-1 (PELV)

## Approval data

UL approvals	UL/C-UL listed UL 508 UL/C-UL Recognized UL 60950-1
--------------	--

## EMC data

Low Voltage Directive	Conformance with Low Voltage Directive 2014/35/EC
Electromagnetic compatibility	Conformance with EMC Directive 2014/30/EU
EMC requirements for noise emission	EN 61000-6-3 EN 61000-6-4
EMC requirements for noise immunity	EN 61000-6-1 EN 61000-6-2
Noise immunity	EN 61000-6-2:2005

## Electrostatic discharge

Standards/regulations	EN 61000-4-2
-----------------------	--------------

## Electrostatic discharge

Contact discharge	4 kV (Test Level 3)
Discharge in air	8 kV (Test Level 3)
Comments	Criterion B

## Electromagnetic HF field

Standards/regulations	EN 61000-4-3
-----------------------	--------------

## Electromagnetic HF field

Frequency range	80 MHz ... 1 GHz
Test field strength	10 V/m
Frequency range	1 GHz ... 2 GHz
Test field strength	10 V/m
Frequency range	2 GHz ... 3 GHz
Test field strength	10 V/m

# Redundancy module - TRIO2-DIODE/12-24DC/2X10/1X20



2907380

<https://www.phoenixcontact.com/pc/products/2907380>

Comments	Criterion A
Fast transients (burst)	
Standards/regulations	EN 61000-4-4
Fast transients (burst)	
Input	2 kV (Test Level 3 - asymmetrical)
Output	2 kV (Test Level 3 - asymmetrical)
Comments	Criterion B
Surge voltage load (surge)	
Standards/regulations	EN 61000-4-5
Input	1 kV (Test Level 3 - symmetrical)
	2 kV (Test Level 4 - asymmetrical)
Output	1 kV (Test Level 2 - symmetrical)
	2 kV (Test Level 3 - asymmetrical)
Comments	Criterion B
Conducted interference	
Standards/regulations	EN 61000-4-6
Conducted interference	
I/O/S	asymmetrical
Frequency range	0.15 MHz ... 80 MHz
Comments	Criterion A
Voltage	10 V (Test Level 3)
Voltage dips	
Standards/regulations	EN 61000-4-11
Emitted interference	
Standards/regulations	EN 61000-6-3
Radio interference voltage in acc. with EN 55011	EN 55011 (EN 55022) Class B, area of application: Industry and residential
Emitted radio interference in acc. with EN 55011	EN 55011 (EN 55022) Class B, area of application: Industry and residential
Criteria	
Criterion A	Normal operating behavior within the specified limits.

# Redundancy module - TRIO2-DIODE/12-24DC/2X10/1X20



2907380

<https://www.phoenixcontact.com/pc/products/2907380>

## Drawings

Block diagram

**2x10 A**

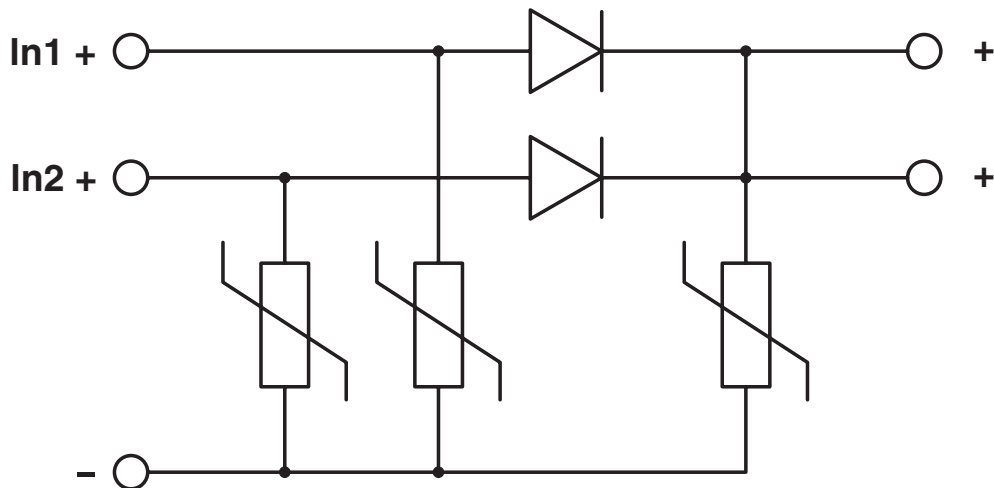

# Redundancy module - TRIO2-DIODE/12-24DC/2X10/1X20



2907380

<https://www.phoenixcontact.com/pc/products/2907380>

## Approvals



**cUL Recognized**  
Approval ID: FILE E 211944



**UL Recognized**  
Approval ID: FILE E 211944



**EAC**  
Approval ID: RU S-DE.BL08.W.00764



**UL Listed**  
Approval ID: FILE E 123528



**cUL Listed**  
Approval ID: FILE E 123528

**DNV**

Approval ID: TAA000011F

**cULus Recognized**

**cULus Listed**

# Redundancy module - TRIO2-DIODE/12-24DC/2X10/1X20



2907380

<https://www.phoenixcontact.com/pc/products/2907380>

## Classifications

### ECLASS

ECLASS-9.0	27371010
ECLASS-10.0.1	27371010
ECLASS-11.0	27371010

### ETIM

ETIM 8.0	EC000683
----------	----------

### UNSPSC

UNSPSC 21.0	32151500
-------------	----------



# Redundancy module - TRIO2-DIODE/12-24DC/2X10/1X20



2907380

<https://www.phoenixcontact.com/pc/products/2907380>

## Environmental Product Compliance

China RoHS	Environmentally friendly use period: unlimited = EFUP-e No hazardous substances above threshold values
------------	---

Phoenix Contact 2023 © - all rights reserved  
<https://www.phoenixcontact.com>

PHOENIX CONTACT GmbH & Co. KG  
Flachmarktstraße 8  
D-32825 Blomberg  
+49 (0) 5235-3 00  
[info@phoenixcontact.com](mailto:info@phoenixcontact.com)