

Uninterruptible power supply - QUINT4-UPS/24DC/24DC/20/EIP



2907074

<https://www.phoenixcontact.com/pc/products/2907074>

Please be informed that the data shown in this PDF document is generated from our Online Catalog. Please find the complete data in the user documentation. Our General Terms of Use for Downloads are valid.



QUINT UPS with IQ Technology, RJ45 communication interfaces (EtherNet/IP™), for DIN rail mounting, input: 24 V DC, output: 24 V DC / 20 A, charging current: 5 A

Product Description

The intelligent QUINT UPS for integration into established industrial networks: your systems continue to be supplied with uninterrupted power, even in the event of a mains failure. The battery management system with IQ Technology and a powerful battery charger ensures superior system availability.

Your advantages

- Easy integration into networks using PROFINET, EtherNet/IP, EtherCAT[®] and USB interfaces
- Evaluation of state of health (SOH) and state of charge (SOC), thanks to the intelligent battery management system (BMS)
- Automatic recognition of the battery capacities and technologies (VRLA-WTR, LI-ION)
- Monitoring of output current and voltage, as well as manual connection and disconnection of the system
- SFB Technology selectively trips standard miniature circuit breakers. Loads connected in parallel continue working.

Commercial Data

Item number	2907074
Packing unit	1 pc
Minimum order quantity	1 pc
Product Key	CMUI43
Catalog Page	Page 319 (C-4-2019)
GTIN	4055626171708
Weight per Piece (including packing)	728 g
Weight per Piece (excluding packing)	535 g
Customs tariff number	85371091
Country of origin	CN

Uninterruptible power supply - QUINT4-UPS/24DC/24DC/20/EIP



2907074

<https://www.phoenixcontact.com/pc/products/2907074>

Technical Data

Input data

Input voltage	24 V DC
Input voltage range	18 V DC ... 30 V DC
	18 V DC ... 32 V DC
Electric strength, max.	35 V DC
Internal input fuse	no
Voltage type of supply voltage	DC
Inrush current	≤ 8 A (≤ 4 ms)
Reverse polarity protection	yes
Fixed backup threshold	22 V DC
Dynamic activation threshold	> 1 V / 100 ms
Switch-on time	max. 3 s
Switch-on time during battery operation (Bat.-Start)	8 s
Voltage drop, input/output	0.4 V DC
Current consumption I_N (U_N , $I_{OUT} = I_N$, $I_{charge} = 0$)	20.1 A
Current consumption I_{max} (U_N , $I_{OUT} = I_{Stat.Boost}$, $I_{charge} = max$)	31.2 A
Current consumption $I_{No-Load}$ (U_N , $I_{OUT} = 0$, $I_{charge} = 0$)	105 mA
Current consumption I_{charge} (U_N , $I_{OUT} = 0$, $I_{charge} = max$)	6.1 A
Power consumption P_N (U_N , $I_{OUT} = I_N$, $I_{charge} = 0$)	475 W
Power consumption P_{max} (U_N , $I_{OUT} = I_{Stat.Boost}$, $I_{charge} = max$)	740 W
Power consumption $P_{No-Load}$ (U_N , $I_{OUT} = 0$, $I_{charge} = 0$)	2.6 W
Power consumption P_{charge} (U_N , $I_{OUT} = 0$, $I_{charge} = max$)	148 W

Output data

Efficiency	typ. 97 %
Number of outputs	1
Short-circuit-proof	yes
No-load proof	yes
Switch-over time	0 ms
UPS connection in parallel	no
UPS connection in series	no
Energy storage device connection in parallel	Yes, 5 (observe line protection)
Energy storage device connection in series	no

Mains operation

Output voltage	24 V DC ($U_{OUT} = U_{IN} - 0.4$ V DC)
Output voltage range	18 V DC ... 30 V DC
	18 V DC ... 32 V DC
Output current I_N	20 A
Static Boost ($I_{Stat.Boost}$)	25 A

Uninterruptible power supply - QUINT4-UPS/24DC/24DC/20/EIP



2907074

<https://www.phoenixcontact.com/pc/products/2907074>

Dynamic Boost ($I_{\text{Dyn.Boost}}$)	30 A (5 s)
Selective Fuse Breaking (I_{SFB})	120 A (15 ms)
Output power P_{OUT} (U_{N} , $I_{\text{OUT}} = I_{\text{N}}$)	480 W
Output power P_{OUT} (U_{N} , $I_{\text{OUT}} = I_{\text{stat.Boost}}$)	600 W

Battery operation

Output voltage	24 V DC ($U_{\text{OUT}} = U_{\text{BAT}} - 0.4 \text{ V DC}$)
Output voltage range	19 V DC ... 32 V DC
Output current I_{N}	20 A
Static Boost ($I_{\text{Stat.Boost}}$)	25 A
Dynamic Boost ($I_{\text{Dyn.Boost}}$)	30 A (5 s)
Selective Fuse Breaking (I_{SFB})	120 A (15 ms)
Output power P_{OUT} (U_{N} , $I_{\text{OUT}} = I_{\text{N}}$)	480 W
Output power P_{OUT} (U_{N} , $I_{\text{OUT}} = I_{\text{stat.Boost}}$)	600 W

Energy storage

End-of-charge voltage	32 V DC
End-of-charge voltage (temperature-compensated)	25 V DC ... 32 V DC
Charging current (configurable)	5 A
Nominal capacity (without additional charger)	3 Ah ... 100 Ah
Max. capacity	135 Ah
Charging time	202.5 h
Buffer time	19 min. (12 Ah)
Deep discharge protection	19.2 V DC
Battery technology	VRLA, VRLA-WTR, LI-ION
Charge characteristic curve	IU_0U
IQ-Technology	yes
Temperature sensor	yes
Temperature compensation (configurable)	42 mV/K

Connection data

Input

Position	1.x
----------	-----

Conductor connection

Connection method	Screw connection
rigid	0.2 mm ² ... 6 mm ²
flexible	0.2 mm ² ... 4 mm ²
flexible with ferrule without plastic sleeve	0.2 mm ² ... 4 mm ²
flexible with ferrule with plastic sleeve	0.2 mm ² ... 4 mm ²
rigid (AWG)	30 ... 10 (Cu)
Stripping length	8 mm (rigid/flexible)
Tightening torque	0.5 Nm ... 0.6 Nm

Uninterruptible power supply - QUINT4-UPS/24DC/24DC/20/EIP



2907074

<https://www.phoenixcontact.com/pc/products/2907074>

Drive form screw head	Slotted L
-----------------------	-----------

Output

Position	2.x
----------	-----

Conductor connection

Connection method	Screw connection
rigid	0.2 mm ² ... 6 mm ²
flexible	0.2 mm ² ... 4 mm ²
flexible with ferrule without plastic sleeve	0.2 mm ² ... 4 mm ²
flexible with ferrule with plastic sleeve	0.2 mm ² ... 4 mm ²
rigid (AWG)	30 ... 10 (Cu)
Stripping length	8 mm (rigid/flexible)
Tightening torque	0.5 Nm ... 0.6 Nm
Drive form screw head	Slotted L

Signal

Position	3.x
----------	-----

Conductor connection

Connection method	Push-in connection
rigid	0.2 mm ² ... 1 mm ²
flexible	0.2 mm ² ... 1 mm ²
flexible with ferrule without plastic sleeve	0.2 mm ² ... 0.75 mm ² 0.5 mm ² (recommended)
flexible with ferrule with plastic sleeve	0.2 mm ² ... 0.75 mm ²
rigid (AWG)	24 ... 16 (Cu)
Stripping length	8 mm (rigid/flexible)

Interfaces

Interface	EtherNet/IP (Modbus/TCP)
Number of interfaces	2
Connection method	RJ45 socket
Locking	Locking clip
Transmission physics	Twisted-Pair
Features	Autonegotiation Autocrossing Half- or full-duplex automatic recognition Optional: manually adjustable
Topology	Star Line
Transmission speed	10 Mbps ... 100 Mbps
Transmission length	max. 100 m

Uninterruptible power supply - QUINT4-UPS/24DC/24DC/20/EIP



2907074

<https://www.phoenixcontact.com/pc/products/2907074>

Cycle time	30 ms (Default)
Access time	≤ 2 s
Supported protocols	EtherNet/IP [□] (Explicit Messaging, Implicit Messaging)
	BootP
	DHCP
	DLR
	Modbus/TCP
	HTTPS (Webserver)
Chipset	Renesas R-IN32M3
Electrical isolation	yes
Device ID	1FF7 _{hex}
Vendor ID	232hex
IP address	192.168.019.023 (configurable)

LED signaling

Types of signaling	DC OK (green)
	Alarm (red)
	Bat.-Mode (yellow)
	SOC (red, green)
	Data (red, green)

Product properties

Product type	Uninterruptible power supply
Product family	QUINT USV
MTBF (IEC 61709, SN 29500)	> 1172000 h (25 °C)
	> 732500 h (40 °C)
	> 373400 h (60 °C)
Environmental protection directive	RoHS Directive 2011/65/EU
	WEEE
	Reach

Insulation characteristics

Protection class	III (without PE)
Degree of pollution	2

Life expectancy (electrolytic capacitors)

Time	192072 h
------	----------

Dimensions

Width	40 mm
Height	130 mm
Depth	125 mm

Installation dimensions

Uninterruptible power supply - QUINT4-UPS/24DC/24DC/20/EIP



2907074

<https://www.phoenixcontact.com/pc/products/2907074>

Installation distance right/left (active)	5 mm / 5 mm ($P_{Out} \geq 50\%$)
Installation distance right/left (passive)	0 mm / 0 mm ($P_{Out} \geq 50\%$)
Installation distance right/left (active, passive)	0 mm / 0 mm ($P_{Out} \leq 50\%$)
Installation distance top/bottom (active)	50 mm / 50 mm ($P_{Out} \geq 50\%$)
Installation distance top/bottom (passive)	40 mm / 20 mm ($P_{Out} \geq 50\%$)
Installation distance top/bottom (active, passive)	40 mm / 20 mm ($P_{Out} \leq 50\%$)

Alternative assembly

Width	123 mm
Height	130 mm
Depth	42 mm

Mounting

Mounting type	DIN rail mounting
Mounting position	On horizontal DIN rail NS 35/7.5 and NS 35/15 acc. to EN 60715

Material specifications

Flammability rating according to UL 94 (housing / terminal blocks)	V0
Housing material	Metal
Hood version	Stainless steel X6Cr17
Side element version	Aluminum AlMg3

Environmental and real-life conditions

Ambient conditions

Degree of protection	IP20
Ambient temperature (operation)	-25 °C ... 70 °C (> 60 °C Derating: 2,5 %/K)
Ambient temperature (storage/transport)	-40 °C ... 85 °C
Ambient temperature (start-up type tested)	-40 °C
Maximum altitude	≤ 4000 m
Climatic class	3K3 (EN 60721)
Max. permissible relative humidity (operation)	≤ 95 % (at 25 °C, non-condensing)
Shock	18 ms, 30g, in each space direction (according to IEC 60068-2-27)
Vibration (operation)	2.3g

Standards and regulations

Protective extra-low voltage

Standards/specifications	IEC 61010-1 (SELV) IEC 61010-2-201 (PELV)
--------------------------	--

Approval data

UL approval

Uninterruptible power supply - QUINT4-UPS/24DC/24DC/20/EIP



2907074

<https://www.phoenixcontact.com/pc/products/2907074>

Identification	UL/C-UL Listed UL 61010-1
UL approval	
Identification	UL/C-UL Listed UL 61010-2-201
UL approval	
Identification	UL/C-UL Listed ANSI/ISA-12.12.01 Class I, Division 2, Groups A, B, C, D T4 (Hazardous Location)
CSA	
Identification	CAN/CSA-C22.2 No. 61010-1-12
CSA	
Identification	CAN/CSA-IEC 61010-2-201
CSA	
Identification	CAN/CSA-C22.2 No. 213 Class I, Division 2, Groups A, B, C, D T4 (Hazardous Location)
CB scheme	
Identification	IEC 61010-1
	IEC 61010-2-201
DNV	
Identification	Class Guideline DNVGL-CG-0339
Note	Location classes: Temperature D (see Application/Limitation), Humidity B, Vibration A/C, EMC B

EMC data

Low Voltage Directive	Conformance with Low Voltage Directive 2014/35/EC
Electromagnetic compatibility	Conformance with EMC Directive 2014/30/EU
EMC requirements for noise emission	EN 61000-6-3
	EN 61000-6-4
EMC requirements for noise immunity	EN 61000-6-1
	EN 61000-6-2
Interference emission	Interference emission in accordance with EN 61000-6-3 (residential and commercial)
Noise emission	Additional basic standard EN 61000-6-5 (immunity in power station), IEC/EN 61850-3 (energy supply)
Noise immunity	Immunity in accordance with EN 61000-6-1 (residential), EN 61000-6-2 (industrial), and EN 61000-6-5 (power station equipment zone), IEC/EN 61850-3 (power supply)
	Immunity in accordance with EN 61000-6-2 (industrial)
Electrostatic discharge	
Standards/regulations	EN 61000-4-2
Electrostatic discharge	
Contact discharge	8 kV (Test Level 4)

Uninterruptible power supply - QUINT4-UPS/24DC/24DC/20/EIP



2907074

<https://www.phoenixcontact.com/pc/products/2907074>

Discharge in air	15 kV (Test Level 4)
Comments	Criterion B

Electromagnetic HF field

Standards/regulations	EN 61000-4-3
-----------------------	--------------

Electromagnetic HF field

Frequency range	80 MHz ... 1 GHz
Test field strength	20 V/m (Test Level 3)
Frequency range	1 GHz ... 6 GHz
Test field strength	10 V/m (Test Level 3)
Frequency range	1 GHz ... 6 GHz
Test field strength	10 V/m (Test Level 3)
Comments	Criterion A

Fast transients (burst)

Standards/regulations	EN 61000-4-4
-----------------------	--------------

Fast transients (burst)

Input	4 kV (Test Level 4 - asymmetrical)
Output	4 kV (Test Level 4 - asymmetrical)
Signal	4 kV (Test Level 4 - asymmetrical)
Comments	Criterion B

Surge voltage load (surge)

Standards/regulations	EN 61000-4-5
Input	1 kV (Test Level 3 - symmetrical)
	2 kV (Test Level 3 - asymmetrical)
Output	1 kV (Test Level 3 - symmetrical)
	2 kV (Test Level 3 - asymmetrical)
Signal	1 kV (Test Level 2 - asymmetrical)
Comments	Criterion B

Conducted interference

Standards/regulations	EN 61000-4-6
-----------------------	--------------

Conducted interference

I/O/S	asymmetrical
Frequency range	0.15 MHz ... 80 MHz
Comments	Criterion A
Voltage	10 V (Test Level 3)

Power frequency magnetic field

Standards/regulations	EN 61000-4-8
Frequency	16.67 Hz
	50 Hz

Uninterruptible power supply - QUINT4-UPS/24DC/24DC/20/EIP



2907074

<https://www.phoenixcontact.com/pc/products/2907074>

	60 Hz
Test field strength	100 A/m
Additional text	60 s
Comments	Criterion A
Frequency	50 Hz
	60 Hz
Frequency range	50 Hz ... 60 Hz
Test field strength	1 kA/m
Additional text	3 s
Frequency	0 Hz
Test field strength	300 A/m
Additional text	DC, 60 s

Criteria

Criterion A	Normal operating behavior within the specified limits.
Criterion B	Temporary impairment to operational behavior that is corrected by the device itself.

Uninterruptible power supply - QUINT4-UPS/24DC/24DC/20/EIP

2907074

<https://www.phoenixcontact.com/pc/products/2907074>

Drawings

Block diagram

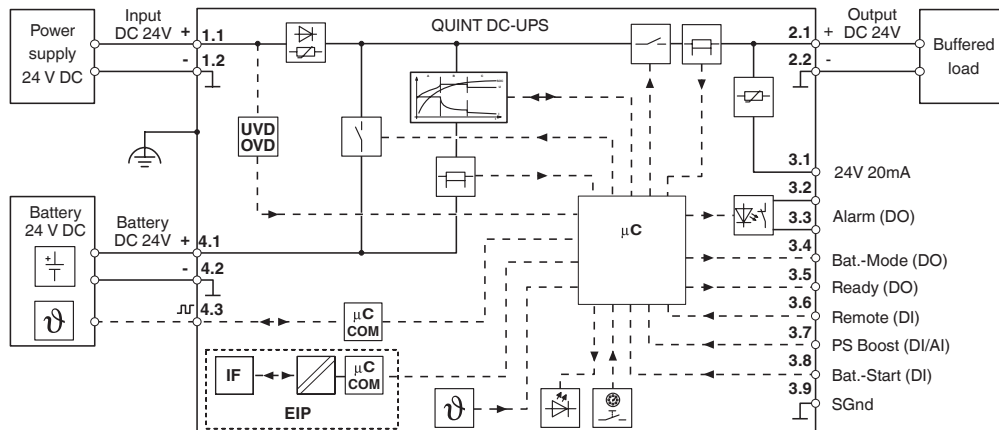

Uninterruptible power supply - QUINT4-UPS/24DC/24DC/20/EIP



2907074

<https://www.phoenixcontact.com/pc/products/2907074>

Approvals



EAC

Approval ID: RU S-DE.BL08.W.00764



UL Listed

Approval ID: FILE E 123528



cUL Listed

Approval ID: FILE E 123528



EAC

Approval ID: RU-DE.B.00184/20

DNV

Approval ID: TAA00002K4



cUL Listed

Approval ID: FILE E 199827



UL Listed

Approval ID: FILE E 199827

cULus Listed

cULus Listed

Uninterruptible power supply - QUINT4-UPS/24DC/24DC/20/EIP



2907074

<https://www.phoenixcontact.com/pc/products/2907074>

Classifications

ECLASS

ECLASS-9.0	27040705
ECLASS-10.0.1	27040705
ECLASS-11.0	27040705

ETIM

ETIM 8.0	EC000382
----------	----------

UNSPSC

UNSPSC 21.0	39121000
-------------	----------

Uninterruptible power supply - QUINT4-UPS/24DC/24DC/20/EIP



2907074

<https://www.phoenixcontact.com/pc/products/2907074>

Environmental Product Compliance

REACH SVHC	Lead 7439-92-1
China RoHS	Environmentally Friendly Use Period = 25; For information on hazardous substances, refer to the manufacturer's declaration available under "Downloads"

Uninterruptible power supply - QUINT4-UPS/24DC/24DC/20/EIP



2907074

<https://www.phoenixcontact.com/pc/products/2907074>

Accessories

Energy storage

Energy storage - UPS-BAT/PB/24DC/4AH - 1274117

<https://www.phoenixcontact.com/pc/products/1274117>



Energy storage, VRLA-AGM, 24 V DC, 4 Ah, automatic detection and communication with QUINT UPS-IQ

Energy storage

Energy storage - UPS-BAT/PB/24DC/7AH - 1274118

<https://www.phoenixcontact.com/pc/products/1274118>



Energy storage, VRLA-AGM, 24 V DC, 7 Ah, automatic detection and communication with QUINT UPS-IQ

Uninterruptible power supply - QUINT4-UPS/24DC/24DC/20/EIP



2907074

<https://www.phoenixcontact.com/pc/products/2907074>

Energy storage

Energy storage - UPS-BAT/PB/24DC/12AH - 1274119

<https://www.phoenixcontact.com/pc/products/1274119>



Energy storage, VRLA-AGM, 24 V DC, 12 Ah, automatic detection and communication with QUINT UPS-IQ

Energy storage

Energy storage - UPS-BAT/VRLA/24DC/20AH - 1109004

<https://www.phoenixcontact.com/pc/products/1109004>



Energy storage, lead AGM, VRLA technology, 24 V DC, 20 Ah, automatic detection and communication with QUINT UPS-IQ

Uninterruptible power supply - QUINT4-UPS/24DC/24DC/20/EIP



2907074

<https://www.phoenixcontact.com/pc/products/2907074>

Configuration software

Configuration software - UPS-CONF - 2320403

<https://www.phoenixcontact.com/pc/products/2320403>



Configuration software for QUINT UPS IQ and TRIO UPS uninterruptible power supplies (available for free under Downloads).

Energy storage

Energy storage - UPS-BAT/VRLA/24DC/ 3.4AH - 2320306

<https://www.phoenixcontact.com/pc/products/2320306>



Energy storage device, lead AGM, VRLA technology, 24 V DC, 3.4 Ah, tool-free battery replacement, automatic detection, and communication with QUINT UPS-IQ

Uninterruptible power supply - QUINT4-UPS/24DC/24DC/20/EIP



2907074

<https://www.phoenixcontact.com/pc/products/2907074>

Energy storage

Energy storage - UPS-BAT/VRLA/24DC/7.2AH - 2320319

<https://www.phoenixcontact.com/pc/products/2320319>



Energy storage device, lead AGM, VRLA technology, 24 V DC, 7.2 Ah, tool-free battery replacement, automatic detection, and communication with QUINT UPS-IQ

Energy storage

Energy storage - UPS-BAT/VRLA/24DC/12AH - 2320322

<https://www.phoenixcontact.com/pc/products/2320322>



Please use the following item in new systems: 1274119.

Energy storage device, lead AGM, VRLA technology, 24 V DC, 12 Ah, tool-free battery replacement, automatic detection, and communication with QUINT UPS-IQ

Uninterruptible power supply - QUINT4-UPS/24DC/24DC/20/EIP



2907074

<https://www.phoenixcontact.com/pc/products/2907074>

Energy storage

Energy storage - UPS-BAT/VRLA/24DC/38AH - 2320335

<https://www.phoenixcontact.com/pc/products/2320335>



Energy storage device, lead AGM, VRLA technology, 24 V DC, 38 Ah, automatic detection, and communication with QUINT UPS-IQ

Energy storage

Energy storage - UPS-BAT/VRLA-WTR/24DC/13AH - 2320416

<https://www.phoenixcontact.com/pc/products/2320416>



Energy storage device, lead AGM, VRLA technology, 24 V DC, 13 Ah, tool-free battery replacement, automatic detection, and communication with QUINT UPS-IQ

Uninterruptible power supply - QUINT4-UPS/24DC/24DC/20/EIP



2907074

<https://www.phoenixcontact.com/pc/products/2907074>

Energy storage

Energy storage - UPS-BAT/VRLA-WTR/24DC/26AH - 2320429

<https://www.phoenixcontact.com/pc/products/2320429>



Energy storage device, lead AGM, VRLA technology, 24 V DC, 26 Ah, tool-free battery replacement, automatic detection, and communication with QUINT UPS-IQ

Energy storage

Energy storage - UPS-BAT/LI-ION/24DC/120WH - 2320351

<https://www.phoenixcontact.com/pc/products/2320351>



Energy storage device, LI-ION technology, 24 V DC, 120 Wh, for ambient temperatures of -20°C ... 60°C, automatic detection and communication with QUINT UPS-IQ

Uninterruptible power supply - QUINT4-UPS/24DC/24DC/20/EIP

2907074

<https://www.phoenixcontact.com/pc/products/2907074>

Energy storage

Energy storage - UPS-BAT/LI-ION/24DC/924WH - 2908232

<https://www.phoenixcontact.com/pc/products/2908232>



Energy storage device, LI-ION technology, 24 V DC, 924 Wh, for ambient temperatures of -25 °C ... 60 °C, automatic detection and communication with QUINT UPS-IQ

Energy storage

Energy storage - UPS-BAT/PB/24DC/20AH - 1348516

<https://www.phoenixcontact.com/pc/products/1348516>



Energy storage, VRLA-AGM, 24 V DC, 20 Ah, automatic detection and communication with QUINT UPS-IQ

Uninterruptible power supply - QUINT4-UPS/24DC/24DC/20/EIP



2907074

<https://www.phoenixcontact.com/pc/products/2907074>

Energy storage

Energy storage - UPS-BAT/PB/24DC/40AH - 1354641

<https://www.phoenixcontact.com/pc/products/1354641>



Energy storage, VRLA-AGM, 24 V DC, 40 Ah, automatic detection and communication with QUINT UPS-IQ

Phoenix Contact 2023 © - all rights reserved
<https://www.phoenixcontact.com>

PHOENIX CONTACT GmbH & Co. KG
Flachsmarktstraße 8
D-32825 Blomberg
+49 (0) 5235-3 00
info@phoenixcontact.com