

2905009

<https://www.phoenixcontact.com/us/products/2905009>

Please be informed that the data shown in this PDF document is generated from our Online Catalog. Please find the complete data in the user documentation. Our General Terms of Use for Downloads are valid.



Primary-switched QUINT DC/DC converter with wide range input for DIN rail mounting with SFB (Selective Fuse Breaking) technology, input: 60-72 V DC, output 24 V DC / 10 A

## Product Description

QUINT DC/DC converter with maximum functionality

DC/DC converters alter the voltage level, regenerate the voltage at the end of long cables or enable the creation of independent supply systems by means of electrical isolation.

QUINT DC/DC converters magnetically and therefore quickly trip circuit breakers with six times the nominal current, for selective and therefore cost-effective system protection. The high level of system availability is additionally ensured, thanks to preventive function monitoring, as it reports critical operating states before errors occur.

## Your advantages

- Reliable starting of difficult loads, thanks to the static POWER BOOST power reserve with up to 125% nominal current permanently
- Preventive function monitoring indicates critical operating states before errors occur
- Constant voltage: output voltage regenerated even at the end of long cables
- Support conversion to various voltage levels
- Electrical isolation: for setting up independent supply systems

## Commercial Data

Item number	2905009
Packing unit	1 pc
Minimum order quantity	1 pc
Sales Key	C13
Product Key	CMDQ43
Catalog Page	Page 294 (C-4-2019)
GTIN	4046356908436
Weight per Piece (including packing)	1,160.5 g
Weight per Piece (excluding packing)	1,190 g
Customs tariff number	85044083
Country of origin	CN

## Technical Data

### Input data

#### DC operation

Nominal input voltage range	60 V DC ... 72 V DC
Input voltage range	42 V DC ... 96 V DC
Wide-range input	yes
Input voltage range DC	42 V DC ... 96 V DC
Voltage type of supply voltage	DC
Inrush current	< 9 A (typical)
Inrush current integral ( $I^2t$ )	0.64 A <sup>2</sup> s
Mains buffering time	typ. 10 ms (60 V DC)
Current consumption	5.6 A (60 V DC) 4.7 A (72 V DC)
Reverse polarity protection	≤ 30 V DC
Protective circuit	Transient surge protection; Varistor
Input fuse	10 A 150 V DC (internal (device protection))

### Output data

Efficiency	> 91 % ( $U_{IN}$ 60 V DC / $U_{OUT}$ 24 V DC) > 91 % ( $U_{IN}$ 72 V DC / $U_{OUT}$ 24 V DC)
Output characteristic	U/I
Nominal output voltage	24 V DC ±1 %
Setting range of the output voltage ( $U_{Set}$ )	18 V DC ... 29.5 V DC (> 24 V DC, constant capacity restricted)
Nominal output current ( $I_N$ )	10 A (-40 °C ... 60 °C)
POWER BOOST ( $I_{Boost}$ )	12.5 A (-40°C ... 40°C permanent, $U_{OUT}$ = 24 V DC )
Selective Fuse Breaking ( $I_{SFB}$ )	60 A (12 ms)
Magnetic circuit breaker tripping	B2 / B4 / B6
Derating	60 °C ... 70 °C (2.5%/K)
Feedback voltage resistance	35 V DC
Protection against overvoltage at the output (OVP)	< 35 V DC
Max. capacitive load	unlimited
Active current limitation	18 A
Control deviation	< 1 % (change in load, static 10 % ... 90 %) < 2 % (change in load, dynamic 10 % ... 90 %) < 0.1 % (change in input voltage ±10 %)
Residual ripple	< 20 mV <sub>PP</sub>
Output power	240 W
Peak switching voltages nominal load	< 10 mV <sub>PP</sub> (20 MHz)
Maximum no-load power dissipation	4 W ( $U_{IN}$ 60 V DC)
Power loss nominal load max.	24 W ( $U_{IN}$ 60 V DC)
Rise time	< 2 ms ( $U_{OUT}$ (10 % ... 90 %))
Connection in parallel	yes, for redundancy and increased capacity

2905009

<https://www.phoenixcontact.com/us/products/2905009>

Connection in series	yes
----------------------	-----

Signal: DC OK active

Output description	$U_{OUT} > 0.9 \times U_N$ : High signal
Switching voltage range	18 V DC ... 24 V DC
Maximum inrush current	< 20 mA (short-circuit-proof)

Signal: POWER BOOST, active

Output description	$I_{OUT} < I_N$ : High signal
Switching voltage range	18 V DC ... 24 V DC
Maximum inrush current	< 20 mA (short-circuit-proof)

Signal:  $U_{IN}$  OK, active

Output description	$U_{IN} > 19.2$ V: High signal
Switching voltage range	18 V DC ... 24 V DC
Maximum inrush current	$\leq 20$ mA (short-circuit-proof)

Signal: DC OK floating

Output description	Relay
Output voltage	$\leq 30$ V AC/DC
Maximum inrush current	$\leq 100$ mA

## Connection data

Input

Connection method	Screw connection
Conductor cross section solid min.	0.2 mm <sup>2</sup>
Conductor cross section solid max.	2.5 mm <sup>2</sup>
Conductor cross section flexible min.	0.2 mm <sup>2</sup>
Conductor cross section flexible max.	2.5 mm <sup>2</sup>
Conductor cross section AWG min.	24
Conductor cross section AWG max.	12
Stripping length	8 mm
Screw thread	M3
Tightening torque, min	0.5 Nm
Tightening torque max	0.6 Nm

Output

Connection method	Screw connection
Conductor cross section solid min.	0.2 mm <sup>2</sup>
Conductor cross section solid max.	2.5 mm <sup>2</sup>
Conductor cross section flexible min.	0.2 mm <sup>2</sup>
Conductor cross section flexible max.	2.5 mm <sup>2</sup>
Conductor cross section AWG min.	24
Conductor cross section AWG max.	12
Stripping length	7 mm
Screw thread	M3

2905009

<https://www.phoenixcontact.com/us/products/2905009>

Tightening torque, min	0.5 Nm
Tightening torque max	0.6 Nm

## Signal

Conductor cross section solid min.	0.2 mm <sup>2</sup>
Conductor cross section solid max.	2.5 mm <sup>2</sup>
Conductor cross section flexible min.	0.2 mm <sup>2</sup>
Conductor cross section flexible max.	2.5 mm <sup>2</sup>
Conductor cross section AWG min.	24
Conductor cross section AWG max.	12
Screw thread	M3
Tightening torque, min	0.5 Nm
Tightening torque max	0.6 Nm

## LED signaling

Types of signaling	LED
	Active switching output
	Relay contact

### Signal output: DC OK active

Status display	"DC OK" LED green
Color	green

### Signal output: POWER BOOST, active

Status display	"BOOST" LED yellow/ $I_{OUT} > I_N$ : LED on
Color	yellow
Note on status display	LED on

### Signal output: $U_{IN}$ OK, active

Status display	LED " $U_{IN} < 0.8 \times U_N$ V" yellow/ $U_{IN} < 0.8 \times U_N$ V DC: LED on
Color	yellow
Note on status display	LED on

### Signal output: DC OK floating

Note on status display	$U_{OUT} > 0.9 \times U_N$ : Contact closed
------------------------	---

## Electrical properties

Number of phases	1.00
Insulation voltage input/output	1.5 kV (type test)
	1 kV (routine test)
Insulation voltage input/output	1 kV (type test)

## Product properties

Product type	DC/DC converters
	QUINT POWER
MTBF (IEC 61709, SN 29500)	> 1349000 h (25 °C)
	> 765000 h (40 °C)

2905009

<https://www.phoenixcontact.com/us/products/2905009>

## Insulation characteristics

Protection class	I
Degree of pollution	2

## Dimensions

Width	48 mm
Height	130 mm
Depth	125 mm

## Installation dimensions

Installation distance right/left	0 mm / 0 mm ( $\leq 70\text{ }^{\circ}\text{C}$ )
Installation distance right/left (active)	15 mm / 15 mm ( $\leq 70\text{ }^{\circ}\text{C}$ )
Installation distance top/bottom	50 mm / 50 mm ( $\leq 70\text{ }^{\circ}\text{C}$ )
Installation distance top/bottom (active)	50 mm / 50 mm ( $\leq 70\text{ }^{\circ}\text{C}$ )

## Alternative assembly

Width	122 mm
Height	130 mm
Depth	51 mm

## Mounting

Mounting type	DIN rail: 35 mm
Assembly instructions	alignable: $P_N \geq 50\%$ , 5 mm horizontally, 15 mm next to active components, 50 mm vertically alignable: $P_N < 50\%$ , 0 mm horizontally, 40 mm vertically top, 20 mm vertically bottom
Mounting position	horizontal DIN rail NS 35, EN 60715
With protective coating	No

## Material specifications

Color	aluminium
Housing material	Metal
Type of housing	Aluminum (AlMg3)
Hood version	Galvanized sheet steel, free from chrome (VI)

## Environmental and real-life conditions

## Ambient conditions

Degree of protection	IP20
Ambient temperature (operation)	-25 °C ... 70 °C (> 60 °C Derating: 2,5 %/K)
Ambient temperature (storage/transport)	-40 °C ... 85 °C
Ambient temperature (start-up type tested)	-40 °C
Climatic class	3K3 (in acc. with EN 60721)
Max. permissible relative humidity (operation)	$\leq 95\%$ (at 25 °C, non-condensing)
Shock	18 ms, 30g, in each space direction (according to IEC 60068-2-27)
Vibration (operation)	< 15 Hz, amplitude $\pm 2.5$ mm (according to IEC 60068-2-6)

	15 Hz ... 150 Hz, 2.3g, 90 min.
--	---------------------------------

## Standards and regulations

Rail applications	EN 50121-4
Standard – Electronic equipment for use in electrical power installations and their assembly into electrical power installations	EN 50178/VDE 0160 (PELV)
Standard - Electrical safety	EN 60950-1/VDE 0805 (SELV)
Standard – Safety extra-low voltage	EN 60950-1 (SELV)
	EN 60204 (PELV)
Standard - Safe isolation	DIN VDE 0100-410

## Approval data

UL approvals	UL/C-UL listed UL 508
	UL/C-UL Recognized UL 60950-1
	UL ANSI/ISA-12.12.01 Class I, Division 2, Groups A, B, C, D (Hazardous Location)

## EMC data

Electromagnetic compatibility	Conformance with EMC Directive 2014/30/EU
EMC requirements for noise emission	EN 61000-6-3
	EN 61000-6-4
EMC requirements for noise immunity	EN 61000-6-1
	EN 61000-6-2
Noise immunity	EN 61000-6-2:2005

## Electrostatic discharge

Standards/regulations	EN 61000-4-2
-----------------------	--------------

## Electrostatic discharge

Contact discharge	8 kV (Test Level 4)
Discharge in air	15 kV (Test Level 4)
Comments	Criterion A

## Electromagnetic HF field

Standards/regulations	EN 61000-4-3
-----------------------	--------------

## Electromagnetic HF field

Frequency range	80 MHz ... 1 GHz
Test field strength	20 V/m (Test Level 3)
Frequency range	1 GHz ... 2 GHz
Test field strength	20 V/m (Test Level 3)
Frequency range	2 GHz ... 3 GHz
Test field strength	10 V/m (Test Level 3)
Comments	Criterion A

## Fast transients (burst)

Standards/regulations	EN 61000-4-4
-----------------------	--------------

2905009

<https://www.phoenixcontact.com/us/products/2905009>

## Fast transients (burst)

Input	4 kV (Test Level 4 - asymmetrical)
Output	2 kV (Test Level 3 - asymmetrical)
Signal	2 kV (Test Level 4 - asymmetrical)
Comments	Criterion A

## Surge voltage load (surge)

Standards/regulations	EN 61000-4-5
Input	2 kV (Test Level 4 - symmetrical)
	4 kV (Test Level 4 - asymmetrical)
Output	1 kV (Test Level 3 - symmetrical)
	2 kV (Test Level 3 - asymmetrical)
Signal	1 kV (Test Level 2 - asymmetrical)
Comments	Criterion A

## Conducted interference

Standards/regulations	EN 61000-4-6
-----------------------	--------------

## Conducted interference

I/O/S	asymmetrical
Frequency range	0.9 MHz ... 80 MHz
Comments	Criterion A
Voltage	10 V (Test Level 3)

## Emitted interference

Standards/regulations	EN 61000-6-3
Radio interference voltage in acc. with EN 55011	EN 55011 (EN 55022) Class B, area of application: Industry and residential
Emitted radio interference in acc. with EN 55011	EN 55011 (EN 55022) Class B, area of application: Industry and residential

## Criteria

Criterion A	Normal operating behavior within the specified limits.
Criterion B	Temporary impairment to operational behavior that is corrected by the device itself.

2905009

<https://www.phoenixcontact.com/us/products/2905009>

## Drawings

Block diagram

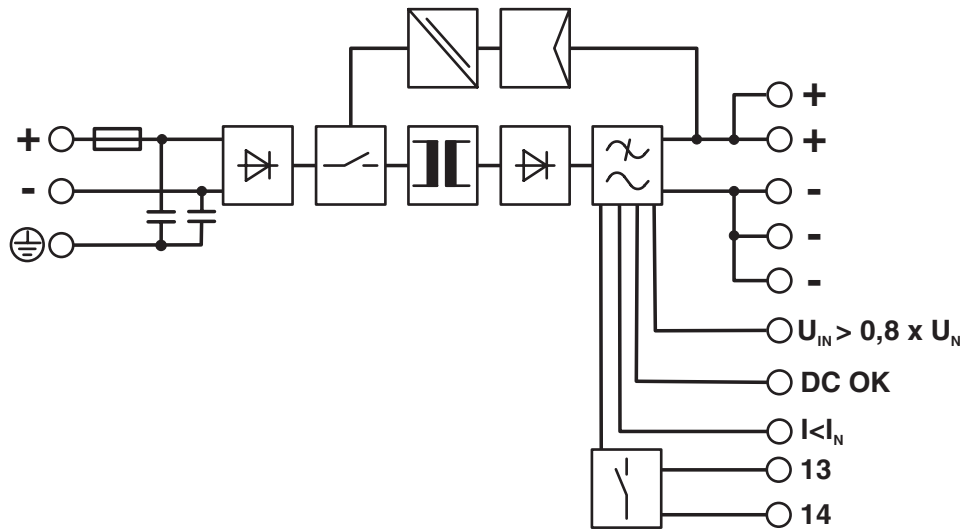



2905009

<https://www.phoenixcontact.com/us/products/2905009>

## Approvals



**cUL Recognized**  
Approval ID: FILE E 211944



**UL Recognized**  
Approval ID: FILE E 211944



**EAC**  
Approval ID: RU S-DE.BL08.W.00764



**UL Listed**  
Approval ID: FILE E 123528



**cUL Listed**  
Approval ID: FILE E 123528



**EAC**  
Approval ID: RU S-DE.BL08.W.00764



**cUL Listed**  
Approval ID: FILE E 199827



**UL Listed**  
Approval ID: FILE E 199827

**cULus Recognized**

**cULus Listed**

**cULus Listed**

# DC/DC converters - QUINT-PS/60-72DC/24DC/10



2905009

<https://www.phoenixcontact.com/us/products/2905009>

## Classifications

### ECLASS

ECLASS-9.0	27210901
ECLASS-10.0.1	27210901
ECLASS-11.0	27040701

### ETIM

ETIM 8.0	EC002046
----------	----------

### UNSPSC

UNSPSC 21.0	39121000
-------------	----------

2905009

<https://www.phoenixcontact.com/us/products/2905009>

## Environmental Product Compliance

REACH SVHC	Lead 7439-92-1
China RoHS	Environmentally Friendly Use Period = 25; For information on hazardous substances, refer to the manufacturer's declaration available under "Downloads"

2905009

<https://www.phoenixcontact.com/us/products/2905009>

## Accessories

### Redundancy module, with protective coating

Redundancy module, with protective coating - QUINT-ORING/24DC/2X10/1X20 - 2320173

<https://www.phoenixcontact.com/us/products/2320173>



Active QUINT redundancy module for DIN rail mounting with Auto Current Balancing ACB technology and monitoring functions, input: 24 V DC, output: 24 V DC/2 x 10 A or 1 x 20 A, including mounted UTA 107/30 universal DIN rail adapter

---

### Mounting adapter

Mounting adapter - UTA 107/30 - 2320089

<https://www.phoenixcontact.com/us/products/2320089>

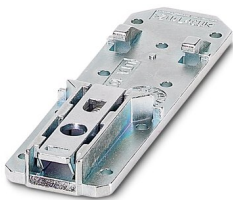

Universal DIN rail adapter

2905009

<https://www.phoenixcontact.com/us/products/2905009>

## Mounting adapter

Mounting adapter - UWA 182/52 - 2938235

<https://www.phoenixcontact.com/us/products/2938235>



Universal wall adapter for securely mounting the device in the event of strong vibrations. The device is screwed directly onto the mounting surface. The universal wall adapter is attached on the top/bottom.

---

## Mounting adapter

Mounting adapter - QUINT-PS-ADAPTERS7/1 - 2938196

<https://www.phoenixcontact.com/us/products/2938196>



Assembly adapter for QUINT-PS... power supply on S7-300 rail

2905009

<https://www.phoenixcontact.com/us/products/2905009>

## Thermomagnetic device circuit breaker

Thermomagnetic device circuit breaker - CB TM1 1A SFB P - 2800836

<https://www.phoenixcontact.com/us/products/2800836>



Thermomagnetic device circuit breaker, 1-pos., tripping characteristic SFB, 1 changeover contact, plug for base element.

---

## Thermomagnetic device circuit breaker

Thermomagnetic device circuit breaker - CB TM1 2A SFB P - 2800837

<https://www.phoenixcontact.com/us/products/2800837>



Thermomagnetic device circuit breaker, 1-pos., tripping characteristic SFB, 1 changeover contact, plug for base element.

2905009

<https://www.phoenixcontact.com/us/products/2905009>

## Thermomagnetic device circuit breaker

Thermomagnetic device circuit breaker - CB TM1 3A SFB P - 2800838

<https://www.phoenixcontact.com/us/products/2800838>



Thermomagnetic device circuit breaker, 1-pos., tripping characteristic SFB, 1 changeover contact, plug for base element.

---

## Thermomagnetic device circuit breaker

Thermomagnetic device circuit breaker - CB TM1 4A SFB P - 2800839

<https://www.phoenixcontact.com/us/products/2800839>



Thermomagnetic device circuit breaker, 1-pos., tripping characteristic SFB, 1 changeover contact, plug for base element.

2905009

<https://www.phoenixcontact.com/us/products/2905009>

## Thermomagnetic device circuit breaker

Thermomagnetic device circuit breaker - CB TM1 5A SFB P - 2800840

<https://www.phoenixcontact.com/us/products/2800840>



Thermomagnetic device circuit breaker, 1-pos., tripping characteristic SFB, 1 changeover contact, plug for base element.

---

## Thermomagnetic device circuit breaker

Thermomagnetic device circuit breaker - CB TM1 12A SFB P - 2800844

<https://www.phoenixcontact.com/us/products/2800844>



Thermomagnetic device circuit breaker, 1-pos., tripping characteristic SFB, 1 changeover contact, plug for base element.



2905009

<https://www.phoenixcontact.com/us/products/2905009>

## Thermomagnetic device circuit breaker

Thermomagnetic device circuit breaker - CB TM1 16A SFB P - 2800845

<https://www.phoenixcontact.com/us/products/2800845>



Thermomagnetic device circuit breaker, 1-pos., tripping characteristic SFB, 1 changeover contact, plug for base element.

---

Phoenix Contact 2023 © - all rights reserved

<https://www.phoenixcontact.com>

Phoenix Contact USA  
586 Fulling Mill Road  
Middletown, PA 17057, United States  
(+717) 944-1300  
[info@phoenixcon.com](mailto:info@phoenixcon.com)