

Power supply unit - QUINT4-PS/1AC/48DC/5



2904610

<https://www.phoenixcontact.com/pc/products/2904610>

Please be informed that the data shown in this PDF document is generated from our Online Catalog. Please find the complete data in the user documentation. Our General Terms of Use for Downloads are valid.



Primary-switched QUINT POWER power supply for DIN rail mounting with free choice of output characteristic curve and SFB (Selective Fuse Breaking) technology, input: 1-phase, output: 48 V DC / 5 A

Product Description

The fourth generation of the high-performance QUINT POWER power supplies ensures superior system availability by means of new functions. Signaling thresholds and characteristic curves can be individually adjusted via the NFC interface. The unique SFB technology and preventive function monitoring of the QUINT POWER power supply increase the availability of your application.

Your advantages

- Preventive function monitoring indicates critical operating states before errors occur
- Signaling thresholds and characteristic curves that can be adjusted via NFC maximize system availability
- Power reserve for easy system extension thanks to static boost with sustained power of up to 125% and ability to start difficult loads thanks to dynamic boost with up to 200% for 5 seconds
- High degree of immunity, thanks to integrated gas-filled surge arrester and mains failure bridging time of more than 20 milliseconds
- Robust design thanks to metal housing and wide temperature range from -40°C to +70°C
- Worldwide use thanks to the wide range input and international approval package

Commercial Data

Item number	2904610
Packing unit	1 pc
Minimum order quantity	1 pc
Product Key	CMPI14
Catalog Page	Page 241 (C-4-2019)
GTIN	4055626355061
Weight per Piece (including packing)	1,145.6 g
Weight per Piece (excluding packing)	1,145 g
Customs tariff number	85044083
Country of origin	TH

Technical Data

Input data

Control input (configurable) Rem	Output power ON/OFF (SLEEP MODE)
Default	Output power ON (>40 k Ω /24 V DC/open bridge between Rem and SGnd)

AC operation

Nominal input voltage range	100 V AC ... 240 V AC
Input voltage range	100 V AC ... 240 V AC -15 % ... +10 %
Derating	< 100 V AC (1 %/V)
Electric strength, max.	300 V AC 60 s
Typical national grid voltage	120 V AC 230 V AC
Voltage type of supply voltage	AC
Inrush current	typ. 16 A (at 25 °C)
Inrush current integral (I^2t)	< 0.5 A ² s
Inrush current limitation	16 A (after 1 ms)
AC frequency range	50 Hz ... 60 Hz -10 % ... +10 %
Frequency range (f_N)	50 Hz ... 60 Hz -10 % ... +10 % 16.7 Hz (acc. to EN 50163)
Mains buffering time	typ. 43 ms (120 V AC) typ. 43 ms (230 V AC)
Current consumption	3.4 A (100 V AC) 2.8 A (120 V AC) 1.5 A (230 V AC) 1.5 A (240 V AC)
Nominal power consumption	271 VA
Protective circuit	Transient surge protection; Varistor, gas-filled surge arrester
Switch-on time	< 1 s
Typical response time	300 ms (from SLEEP MODE)
Input fuse	8 A (slow-blow, internal)
Recommended breaker for input protection	10 A ... 16 A (Characteristic B, C, D, K or comparable)
Discharge current to PE	< 3.5 mA 0.6 mA (264 V AC, 60 Hz)

DC operation

Nominal input voltage range	110 V DC ... 250 V DC
Input voltage range	110 V DC ... 250 V DC -18 % ... +40 %
Derating	< 110 V DC (1 %/V)
Voltage type of supply voltage	DC
Current consumption	3 A (110 V DC) 1.3 A (250 V DC)

Output data

Efficiency	typ. 92.3 % (120 V AC)
	typ. 93.5 % (230 V AC)
Output characteristic	U/I Advanced
	Smart HICCUP
	FUSE MODE
Nominal output voltage	48 V DC
Setting range of the output voltage (U_{Set})	48 V DC ... 56 V DC (constant capacity)
Nominal output current (I_N)	5 A
Static Boost ($I_{Stat.Boost}$)	6.25 A
Dynamic Boost ($I_{Dyn.Boost}$)	10 A (5 s)
Selective Fuse Breaking (I_{SFB})	30 A (15 ms)
Magnetic circuit breaker tripping	A1...A6 / B2 / C1...C2 / Z1...Z6
Derating	> 60 °C ... 70 °C (2.5%/K)
Feedback voltage resistance	≤ 60 V DC
Protection against overvoltage at the output (OVP)	≤ 60 V DC
Control deviation	< 0.5 % (Static load change 10 % ... 90 %)
	< 4 % (Dynamic load change 10 % ... 90 %, (10 Hz))
	< 0.25 % (change in input voltage ±10 %)
Residual ripple	< 70 mV _{PP} (with nominal values)
Short-circuit-proof	yes
No-load proof	yes
Output power	240 W
	300 W
	480 W
Apparent power	120 V, $U_{OUT} = 48$ V, $I_{OUT} = \text{stat. Boost}$
	230 V, $U_{OUT} = 48$ V, $I_{OUT} = \text{stat. Boost}$
Maximum no-load power dissipation	< 3 W (120 V AC)
	< 3 W (230 V AC)
Power loss nominal load max.	< 19 W (120 V AC)
	< 16 W (230 V AC)
Power dissipation SLEEP MODE	< 3 W (120 V AC)
	< 3 W (230 V AC)
Crest factor	typ. 1.5 (120 V AC)
	typ. 1.64 (230 V AC)
Rise time	< 1 s ($U_{Out} = 10$ % ... 90 %)
Connection in parallel	yes, for redundancy and increased capacity
Connection in series	yes

Signal

Signal ground SGnd	Reference potential for Out1, Out2, and Rem
--------------------	---

Signal Out 1 (configurable)

Digital	24 V DC 20 mA
---------	---------------

Power supply unit - QUINT4-PS/1AC/48DC/5



2904610

<https://www.phoenixcontact.com/pc/products/2904610>

Default	24 V DC 20 mA 24 V DC for $U_{Out} > 0.9 \times U_{Set}$
Signal Out 2 (configurable)	
Digital	24 V DC 20 mA
Analog	4 mA ... 20 mA $\pm 5\%$ (Load $\leq 400 \Omega$)
Default	24 V DC 20 mA 24 V DC for $P_{Out} < P_N$
Signal relay 13/14 (configurable)	
Default	closed ($U_{out} > 0.9 U_{Set}$)
Digital	24 V DC 1 A
	30 V AC/DC 0.5 A

Connection data

Input

Connection method	Screw connection
Conductor cross section solid min.	0.2 mm ²
Conductor cross section solid max.	2.5 mm ²
Conductor cross section flexible min.	0.2 mm ²
Conductor cross section flexible max.	2.5 mm ²
Single conductor/flexible terminal point with ferrule with plastic sleeve, min.	0.25 mm ²
Single conductor/flexible terminal point with ferrule with plastic sleeve, max.	2.5 mm ²
Single conductor/flexible terminal point with ferrule without plastic sleeve, min.	0.25 mm ²
Single conductor/flexible terminal point with ferrule without plastic sleeve, max.	2.5 mm ²
Conductor cross section AWG min.	24
Conductor cross section AWG max.	14
Stripping length	6.5 mm
Tightening torque, min	0.5 Nm
Tightening torque max	0.6 Nm

Output

Connection method	Screw connection
Conductor cross section solid min.	0.2 mm ²
Conductor cross section solid max.	2.5 mm ²
Conductor cross section flexible min.	0.2 mm ²
Conductor cross section flexible max.	2.5 mm ²
Single conductor/flexible terminal point with ferrule with plastic sleeve, min.	0.25 mm ²
Single conductor/flexible terminal point with ferrule with plastic sleeve, max.	2.5 mm ²
Single conductor/flexible terminal point with ferrule without plastic sleeve, min.	0.25 mm ²
Single conductor/flexible terminal point with ferrule without plastic sleeve, max.	2.5 mm ²

Power supply unit - QUINT4-PS/1AC/48DC/5



2904610

<https://www.phoenixcontact.com/pc/products/2904610>

Conductor cross section AWG min.	24
Conductor cross section AWG max.	14
Stripping length	6.5 mm
Tightening torque, min	0.5 Nm
Tightening torque max	0.6 Nm

Signal

Connection method	Push-in connection
Conductor cross section solid min.	0.2 mm ²
Conductor cross section solid max.	1 mm ²
Conductor cross section flexible min.	0.2 mm ²
Conductor cross section flexible max.	1.5 mm ²
Single conductor/flexible terminal point with ferrule with plastic sleeve, min.	0.2 mm ²
Single conductor/flexible terminal point with ferrule with plastic sleeve, max.	0.75 mm ²
Single conductor/flexible terminal point with ferrule without plastic sleeve, min.	0.2 mm ²
Single conductor/flexible terminal point with ferrule without plastic sleeve, max.	1.5 mm ²
Conductor cross section AWG min.	24
Conductor cross section AWG max.	16
Stripping length	8 mm

LED signaling

Types of signaling	LED
	Floating signal contact
	Active signal output Out1 (digital, configurable)
	Active signal output Out2 (analog, configurable)
	Remote contact
	Signal ground SGnd

Signal output

P _{Out}	> 100 % (LED lights up yellow, output power > 240 W)
	> 75 % (LED lights up green, output power > 180 W)
	> 50 % (LED lights up green, output power > 120 W)
	> 0.9 × U _{Set} (LED lights up green)
	< 0.9 × U _{Set} (LED flashes green)

Electrical properties

Number of phases	1.00
Insulation voltage input/output	4 kV AC (type test)
	2 kV AC (routine test)
Insulation voltage output / PE	0.5 kV DC (type test)
	0.5 kV DC (routine test)
Insulation voltage input / PE	3.5 kV AC (type test)

Power supply unit - QUINT4-PS/1AC/48DC/5



2904610

<https://www.phoenixcontact.com/pc/products/2904610>

Switching frequency	2.4 kV AC (routine test)
	90 kHz ... 110 kHz (Auxiliary converter stage)
	52 kHz ... 300 kHz (Main converter stage)
	35 kHz ... 700 kHz (PFC stage)

Product properties

Product type	Power supply
Product family	QUINT POWER
MTBF (IEC 61709, SN 29500)	> 1242000 h (25 °C)
	> 784000 h (40 °C)
	> 374000 h (60 °C)
Environmental protection directive	RoHS Directive 2011/65/EU
	WEEE
	Reach

Insulation characteristics

Protection class	I
Degree of pollution	2

Life expectancy (electrolytic capacitors)

Current	2.5 A
Temperature	40 °C
Time	326000 h
Additional text	120 V AC

Life expectancy (electrolytic capacitors)

Current	2.5 A
Temperature	40 °C
Time	321000 h
Additional text	230 V AC

Life expectancy (electrolytic capacitors)

Current	5 A
Temperature	25 °C
Time	452000 h
Additional text	120 V AC

Life expectancy (electrolytic capacitors)

Current	5 A
Temperature	25 °C
Time	618000 h
Additional text	230 V AC

Life expectancy (electrolytic capacitors)

Current	5 A
Temperature	40 °C
Time	159000 h

Power supply unit - QUINT4-PS/1AC/48DC/5



2904610

<https://www.phoenixcontact.com/pc/products/2904610>

Additional text	120 V AC
Life expectancy (electrolytic capacitors)	
Current	5 A
Temperature	40 °C
Time	218000 h
Additional text	230 V AC

Dimensions

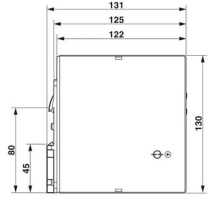
Dimensional drawing	
Width	50 mm
Height	130 mm
Depth	125 mm

Installation dimensions

Installation distance right/left	5 mm / 5 mm
Installation distance top/bottom	50 mm / 50 mm

Alternative assembly

Width	122 mm
Height	130 mm
Depth	53 mm

Mounting

Mounting type	DIN rail: 35 mm
Assembly instructions	alignable: $P_N \geq 50\%$, 5 mm horizontally, 15 mm next to active components, 50 mm vertically alignable: $P_N < 50\%$, 0 mm horizontally, 40 mm vertically top, 20 mm vertically bottom
Mounting position	horizontal DIN rail NS 35, EN 60715
With protective coating	No

Material specifications

Flammability rating according to UL 94 (housing / terminal blocks)	V0
Housing material	Metal
Hood version	Stainless steel X6Cr17
Side element version	Aluminum

Environmental and real-life conditions

Ambient conditions

Power supply unit - QUINT4-PS/1AC/48DC/5



2904610

<https://www.phoenixcontact.com/pc/products/2904610>

Degree of protection	IP20
Ambient temperature (operation)	-25 °C ... 70 °C (> 60 °C Derating: 2,5 %/K)
Ambient temperature (storage/transport)	-40 °C ... 85 °C
Ambient temperature (start-up type tested)	-40 °C
Maximum altitude	≤ 5000 m (> 2000 m, observe derating)
Climatic class	3K3 (in acc. with EN 60721)
Max. permissible relative humidity (operation)	≤ 95 % (at 25 °C, non-condensing)
Shock	18 ms, 30g, in each space direction (according to IEC 60068-2-27)
Vibration (operation)	5 Hz ... 100 Hz resonance search 2.3g, 90 min., resonance frequency 2.3g, 90 min. (according to DNV GL Class C)

Standards and regulations

Rail applications	EN 50121-3-2
	EN 50121-4
	EN 50121-5
	IEC 62236-3-2
	IEC 62236-4
	IEC 62236-5
HART FSK Physical Layer Test Specification Compliance	Output voltage U_{Out} compliant
Standard – Limitation of mains harmonic currents	EN 61000-3-2
Standard - Electrical safety	IEC 61010-2-201 (SELV)
Standard – Safety extra-low voltage	IEC 61010-1 (SELV)
	IEC 61010-2-201 (PELV)
Standard - Safe isolation	IEC 61558-2-16
	IEC 61010-2-201
Standard - safety for equipment for measurement, control, and laboratory use	IEC 61010-1
Standard - Safety of transformers	EN 61558-2-16
Battery charging	DIN 41773-1
Approval - requirement of the semiconductor industry with regard to mains voltage dips	SEMI F47-0706, EN 61000-4-11

Overvoltage category

EN 61010-1	II (≤ 5000 m)
EN 62477-1	III (≤ 2000 m)

Approval data

CSA	CAN/CSA-C22.2 No. 60950-1-07
	CSA-C22.2 No. 107.1-01
UL approvals	UL Listed UL 508
	UL/C-UL Recognized UL 60950-1
	UL ANSI/ISA-12.12.01 Class I, Division 2, Groups A, B, C, D (Hazardous Location)

EMC data

Power supply unit - QUINT4-PS/1AC/48DC/5



2904610

<https://www.phoenixcontact.com/pc/products/2904610>

Low Voltage Directive	Conformance with Low Voltage Directive 2014/35/EC
Electromagnetic compatibility	Conformance with EMC Directive 2014/30/EU
EMC requirements for noise emission	EN 61000-6-3
	EN 61000-6-4
EMC requirements for noise immunity	EN 61000-6-1
	EN 61000-6-2
EMC requirements, power plant	IEC 61850-3
	EN 61000-6-5
Conducted noise emission	EN 55016
	EN 61000-6-3 (Class B)
Interference emission	Interference emission in accordance with EN 61000-6-3 (residential and commercial) and EN 61000-6-4 (industrial)
Noise emission	Additional basic standard EN 61000-6-5 (immunity in power station), IEC/EN 61850-3 (energy supply)
Noise emission	EN 55016
	EN 61000-6-3 (Class B)
Noise immunity	Immunity in accordance with EN 61000-6-1 (residential), EN 61000-6-2 (industrial), and EN 61000-6-5 (power station equipment zone), IEC/EN 61850-3 (power supply)

Harmonic currents

Standards/regulations	EN 61000-3-2
	EN 61000-3-2 (Class A)
Frequency range	0 kHz ... 2 kHz

Flicker

Standards/regulations	EN 61000-3-3
	EN 61000-3-3
Frequency range	0 kHz ... 2 kHz

Electrostatic discharge

Standards/regulations	EN 61000-4-2
-----------------------	--------------

Electrostatic discharge

Contact discharge	8 kV (Test Level 4)
Discharge in air	15 kV (Test Level 4)
Comments	Criterion A

Electromagnetic HF field

Standards/regulations	EN 61000-4-3
-----------------------	--------------

Electromagnetic HF field

Frequency range	80 MHz ... 1 GHz
Test field strength	20 V/m (Test Level 3)
Frequency range	1 GHz ... 6 GHz
Test field strength	10 V/m (Test Level 3)
Frequency range	1 GHz ... 6 GHz
Test field strength	10 V/m (Test Level 3)

Power supply unit - QUINT4-PS/1AC/48DC/5



2904610

<https://www.phoenixcontact.com/pc/products/2904610>

Comments	Criterion A
----------	-------------

Fast transients (burst)

Standards/regulations	EN 61000-4-4
-----------------------	--------------

Fast transients (burst)

Input	4 kV (Test Level 4 - asymmetrical)
Output	4 kV (Test Level 4 - asymmetrical)
Signal	4 kV (Test Level 4 - asymmetrical)
Comments	Criterion A

Surge voltage load (surge)

Input	3 kV (Test Level 4 - symmetrical)
	6 kV (Test Level 4 - asymmetrical)
Output	1 kV (Test Level 3 - symmetrical)
	2 kV (Test Level 3 - asymmetrical)
Signal	4 kV (Test Level 4 - asymmetrical)
Comments	Criterion A

Conducted interference

Standards/regulations	EN 61000-4-6
-----------------------	--------------

Conducted interference

I/O/S	asymmetrical
Frequency range	0.15 MHz ... 80 MHz
Comments	Criterion A
Voltage	10 V (Test Level 3)

Power frequency magnetic field

Standards/regulations	EN 61000-4-8
Frequency	16.7 Hz
	50 Hz
	60 Hz
Test field strength	100 A/m
Additional text	60 s
Comments	Criterion A
Frequency	50 Hz
	60 Hz
Frequency range	50 Hz ... 60 Hz
Test field strength	1 kA/m
Additional text	3 s
Frequency	0 Hz
Test field strength	300 A/m
Additional text	DC, 60 s

Voltage dips

Standards/regulations	EN 61000-4-11
-----------------------	---------------

Power supply unit - QUINT4-PS/1AC/48DC/5



2904610

<https://www.phoenixcontact.com/pc/products/2904610>

Voltage	230 V AC
Frequency	50 Hz
Voltage dip	70 %
Number of periods	0.5 / 1 / 25 periods
Additional text	Test Level 2
Comments	Criterion A: 0.5 / 1 / 25 periods
Voltage dip	40 %
Number of periods	5 / 10 / 50 periods
Additional text	Test Level 2
Comments	Criterion A
Voltage dip	0 %
Number of periods	0,5 / 1 / 5 / 50 / 250 periods
Additional text	Test Level 2
Comments	Criterion A: 0.5 / 1 period Criterion B: 5 / 50 / 250 periods

Pulse-shape magnetic field

Standards/regulations	EN 61000-4-9
Test field strength	1000 A/m
Comments	Criterion A

Attenuated sinusoidal oscillations (ring wave)

Standards/regulations	EN 61000-4-12
Input	2 kV (Test Level 4 - symmetrical) 4 kV (Test Level 4 - asymmetrical)
Comments	Criterion A

Asymmetrical conducted disturbance variables

Standards/regulations	EN 61000-4-16
Test level 1	15 Hz 150 Hz (Test Level 4)
Voltage	30 V 3 V
Test level 2	150 Hz 1.5 kHz (Test Level 4)
Voltage	3 V
Test level 3	1.5 kHz 15 kHz (Test Level 4)
Voltage	3 V 30 V
Test level 4	15 kHz 150 kHz (Test Level 4)
Voltage	30 V
Test level 5	16.7 Hz 50 Hz 60 Hz (Test Level 4)
Voltage	30 V (Permanent)
Test level 6	16.7 Hz 50 Hz 60 Hz (Test Level 4)
Voltage	300 V (1 s)
Comments	Criterion A

Attenuated oscillating wave

Standards/regulations	EN 61000-4-18
Input, output (test level 1)	100 kHz 1 MHz (Test Level 3 - symmetrical)

Power supply unit - QUINT4-PS/1AC/48DC/5



2904610

<https://www.phoenixcontact.com/pc/products/2904610>

Voltage	1 kV
Input, output (test level 2)	10 MHz
Voltage	1 kV
Input, output (test level 3)	100 kHz 1 MHz (Test Level 3 - asymmetrical)
Voltage	2.5 kV
Signals (test level 1)	100 kHz 1 MHz (Test Level 3 - symmetrical)
Voltage	1 kV
Signals (test level 2)	100 kHz 1 MHz (Test Level 3 - asymmetrical)
Voltage	2.5 kV
Comments	Criterion A

Attenuated oscillating magnetic field

Standards/regulations	EN 61000-4-10
Test field strength	110 A/m
Test level 1	100 kHz
Test field strength	110 A/m
Test level 2	1 MHz
Comments	Criterion A

Criteria

Criterion A	Normal operating behavior within the specified limits.
Criterion B	Temporary impairment to operational behavior that is corrected by the device itself.
Criterion C	Temporary adverse effects on the operating behavior, which the device corrects automatically or which can be restored by actuating the operating elements.

Power supply unit - QUINT4-PS/1AC/48DC/5



2904610

<https://www.phoenixcontact.com/pc/products/2904610>

Drawings

Diagram

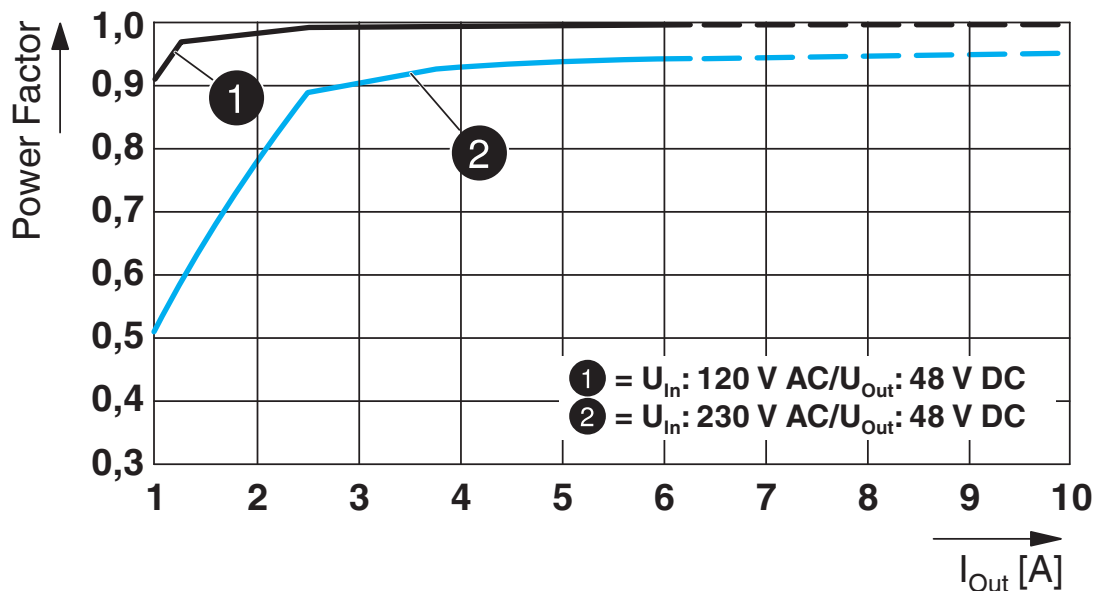

Block diagram

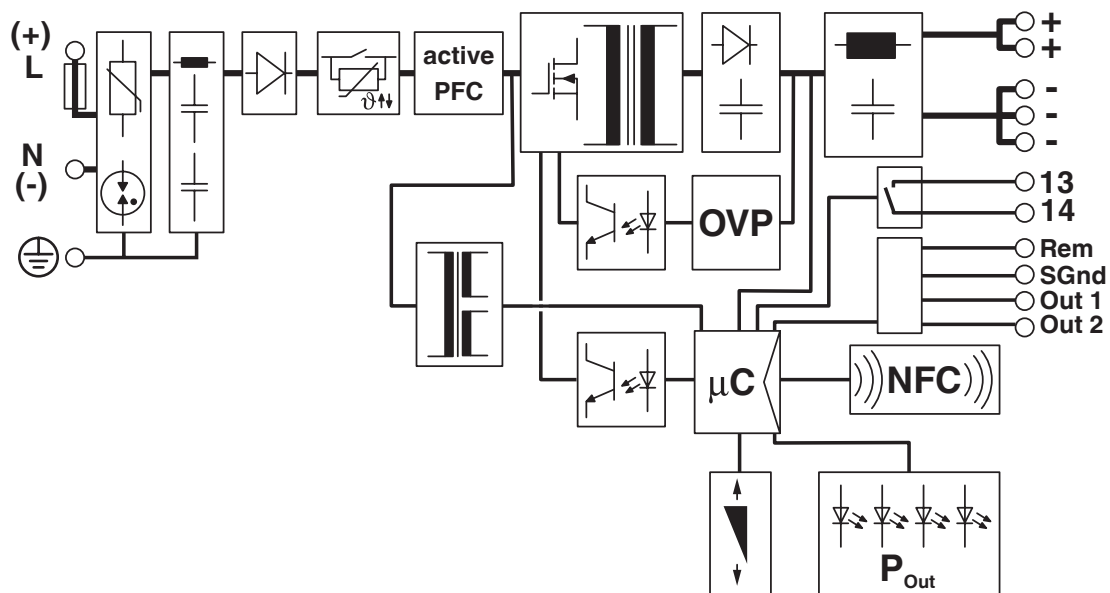

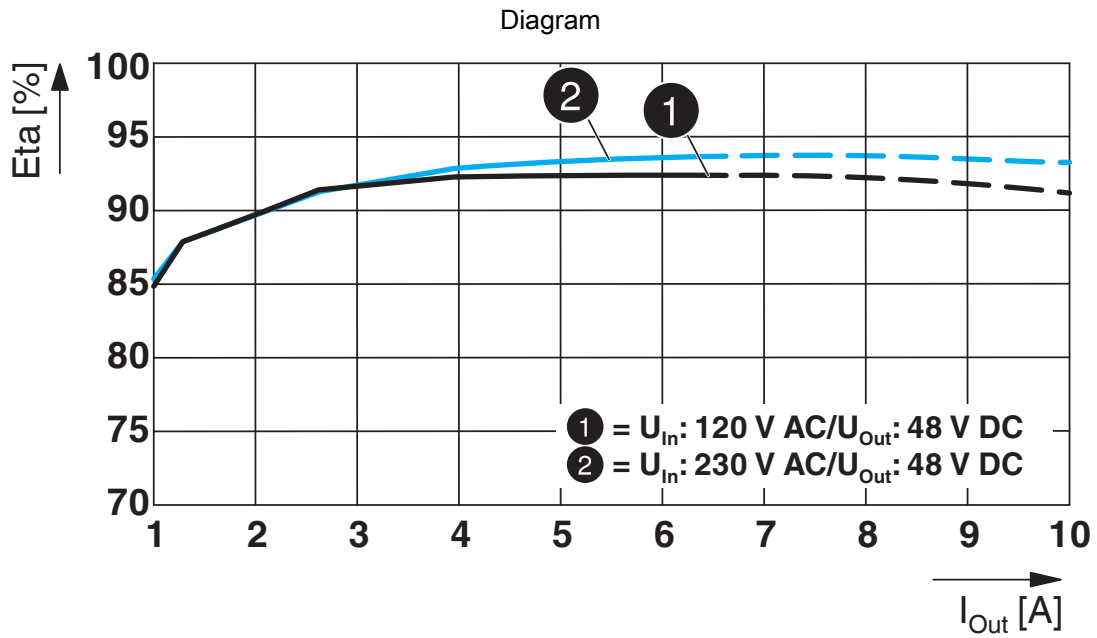

Schematic diagram

Housing

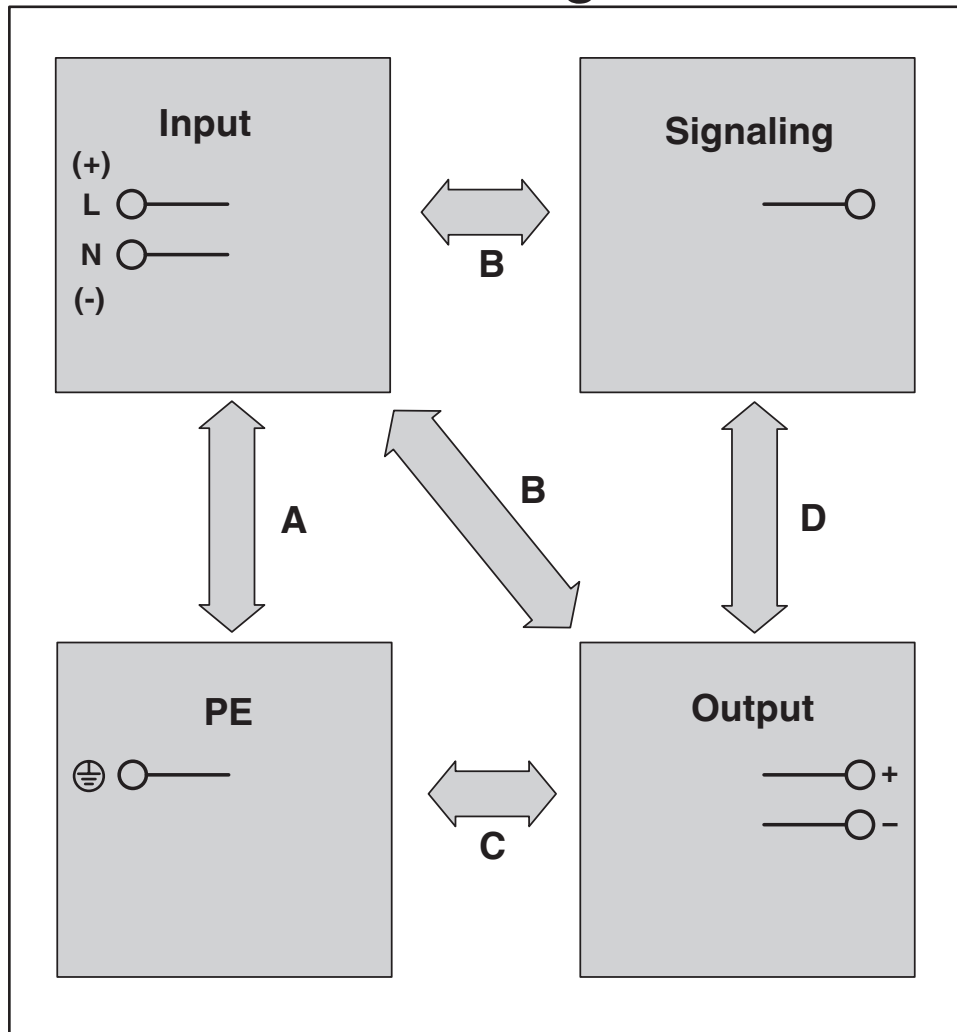

Power supply unit - QUINT4-PS/1AC/48DC/5



2904610

<https://www.phoenixcontact.com/pc/products/2904610>

Diagram

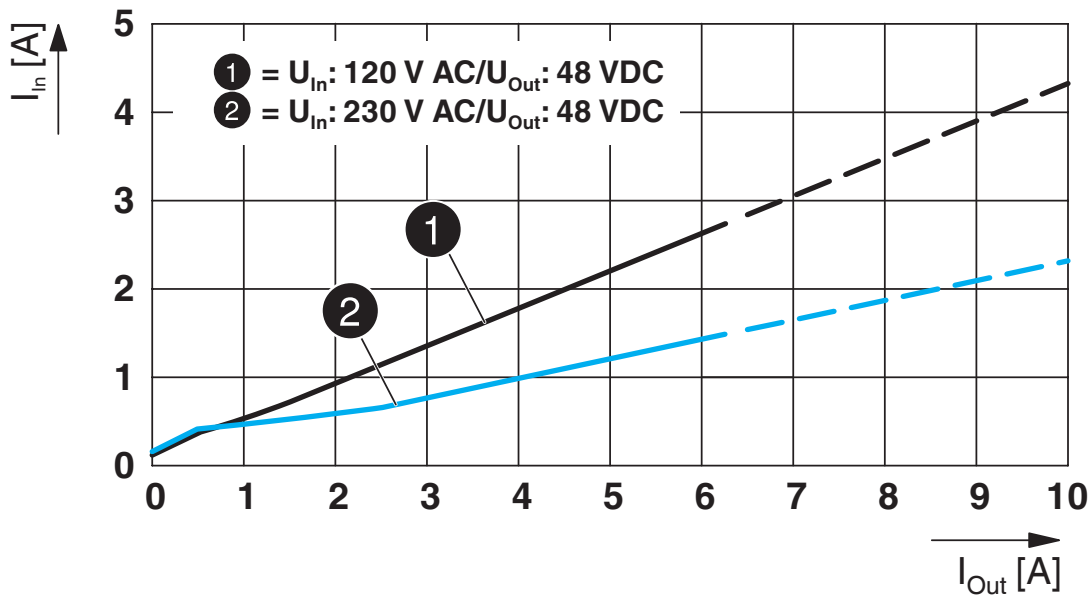

Dimensional drawing

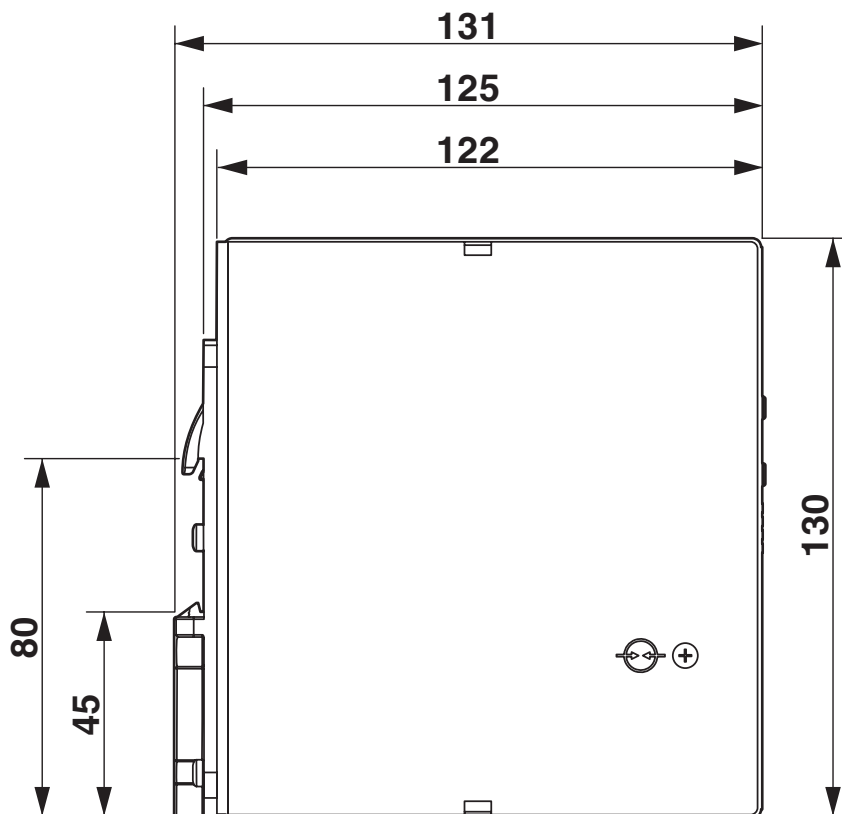

Power supply unit - QUINT4-PS/1AC/48DC/5



2904610

<https://www.phoenixcontact.com/pc/products/2904610>

Approvals



cUL Recognized
Approval ID: FILE E 211944



UL Recognized
Approval ID: FILE E 211944



IECEE CB Scheme
Approval ID: SI-8858



EAC
Approval ID: RU S-DE.BL08.W.00764



LR
Approval ID: 17-20107-03



NK
Approval ID: TA21182M



UL Listed
Approval ID: FILE E 123528



cUL Listed
Approval ID: FILE E 123528

ABS

Approval ID: 20-1973616-PDA



EAC
Approval ID: RU S-DE.BL08.W.00764

DNV

Approval ID: TAA00000BV



BV
Approval ID: 44621/A1 BV

Power supply unit - QUINT4-PS/1AC/48DC/5



2904610

<https://www.phoenixcontact.com/pc/products/2904610>



cUL Listed

Approval ID: FILE E 199827



UL Listed

Approval ID: FILE E 199827

cULus Recognized

cULus Listed

cULus Listed

Power supply unit - QUINT4-PS/1AC/48DC/5



2904610

<https://www.phoenixcontact.com/pc/products/2904610>

Classifications

ECLASS

ECLASS-9.0	27040701
ECLASS-10.0.1	27040701
ECLASS-11.0	27040701

ETIM

ETIM 8.0	EC002540
----------	----------

UNSPSC

UNSPSC 21.0	39121000
-------------	----------

Power supply unit - QUINT4-PS/1AC/48DC/5



2904610

<https://www.phoenixcontact.com/pc/products/2904610>

Environmental Product Compliance

REACH SVHC	Lead 7439-92-1
China RoHS	Environmentally Friendly Use Period = 25; For information on hazardous substances, refer to the manufacturer's declaration available under "Downloads"

Power supply unit - QUINT4-PS/1AC/48DC/5



2904610

<https://www.phoenixcontact.com/pc/products/2904610>

Accessories

Mounting adapter

Mounting adapter - UWA 182/52 - 2938235

<https://www.phoenixcontact.com/pc/products/2938235>



Universal wall adapter for securely mounting the device in the event of strong vibrations. The device is screwed directly onto the mounting surface. The universal wall adapter is attached on the top/bottom.

Mounting adapter

Mounting adapter - UWA 130 - 2901664

<https://www.phoenixcontact.com/pc/products/2901664>



2-piece universal wall adapter for securely mounting the device in the event of strong vibrations. The profiles that are screwed onto the side of the device are screwed directly onto the mounting surface. The universal wall adapter is attached on the left/right.

Power supply unit - QUINT4-PS/1AC/48DC/5

2904610

<https://www.phoenixcontact.com/pc/products/2904610>

Mounting adapter

Mounting adapter - QUINT-PS-ADAPTERS7/1 - 2938196

<https://www.phoenixcontact.com/pc/products/2938196>

Assembly adapter for QUINT-PS... power supply on S7-300 rail



Programming adapter

Programming adapter - TWN4 MIFARE NFC USB ADAPTER - 2909681

<https://www.phoenixcontact.com/pc/products/2909681>

Near Field Communication (NFC) programming adapter with USB interface for the wireless configuration of NFC-capable products from Phoenix Contact with software. A separate USB driver is not required.



Power supply unit - QUINT4-PS/1AC/48DC/5

2904610

<https://www.phoenixcontact.com/pc/products/2904610>

Type 3 surge protection device

Type 3 surge protection device - PLT-SEC-T3-230-FM-UT - 2907919

<https://www.phoenixcontact.com/pc/products/2907919>



Type 2/3 surge protection, consisting of protective plug and base element with screw connection. For single-phase power supply network with integrated status indicator and remote signaling. Nominal voltage: 230 V AC/DC

Type 3 surge protection device

Type 3 surge protection device - PLT-SEC-T3-60-FM-UT - 2907917

<https://www.phoenixcontact.com/pc/products/2907917>



Type 3 surge protection, consisting of protective plug and base element, with integrated status indicator and remote signaling for single-phase power supply networks. Nominal voltage: 60 V AC/DC

Power supply unit - QUINT4-PS/1AC/48DC/5



2904610

<https://www.phoenixcontact.com/pc/products/2904610>

Type 3 surge protection device

Type 3 surge protection device - PLT-SEC-T3-230-FM-PT - 2907928

<https://www.phoenixcontact.com/pc/products/2907928>



Type 2/3 surge protection, consisting of protective plug and base element with Push-in connection. For single-phase power supply network with integrated status indicator and remote signaling. Nominal voltage: 230 V AC/DC

Type 3 surge protection device

Type 3 surge protection device - PLT-SEC-T3-60-FM-PT - 2907926

<https://www.phoenixcontact.com/pc/products/2907926>



Type 3 surge protection, consisting of protective plug and base element, with integrated status indicator and remote signaling for single-phase power supply networks. Nominal voltage: 60 V AC/DC

Phoenix Contact 2023 © - all rights reserved
<https://www.phoenixcontact.com>

PHOENIX CONTACT GmbH & Co. KG
Flachsmarktstraße 8
D-32825 Blomberg
+49 (0) 5235-3 00
info@phoenixcontact.com