

# Redundancy module - TRIO-DIODE/12-24DC/2X10/1X20



2866514

<https://www.phoenixcontact.com/pc/products/2866514>

Please be informed that the data shown in this PDF document is generated from our Online Catalog. Please find the complete data in the user documentation. Our General Terms of Use for Downloads are valid.

Redundancy module with function monitoring, 12 ... 24 V DC, 2x 10 A, 1x 20 A



## Product Description

TRIO DIODE is the DIN-rail mountable redundancy module from the TRIO POWER product range.

Using the redundancy module, it is possible for two power supply units of the same type connected in parallel on the output side to increase performance or for redundancy to be 100 % isolated from one another.

Redundant systems are used in systems that place particularly high demands on operational reliability. The connected power supply units must be large enough that the total current requirements of all loads can be met by one power supply unit. The redundant structure of the power supply therefore ensures long-term, permanent system availability.

In the event of an internal device fault or failure of the mains power supply on the primary side, the other device automatically takes over the entire power supply of the loads without interruption. The floating signal contact and LED immediately indicate the loss of redundancy.

## Your advantages

- Flexible mounting by simply snapping onto the DIN rail
- Save energy
- Rugged design
- Permanent monitoring of redundancy
- Consistent redundancy up to the load

## Commercial Data

Item number	2866514
Packing unit	1 pc
Minimum order quantity	1 pc
Product Key	CMRT43
Catalog Page	Page 210 (C-6-2015)
GTIN	4046356492034
Weight per Piece (including packing)	505 g
Weight per Piece (excluding packing)	370 g
Customs tariff number	85049090
Country of origin	CN

# Redundancy module - TRIO-DIODE/12-24DC/2X10/1X20



2866514

<https://www.phoenixcontact.com/pc/products/2866514>

## Technical Data

### Input data

#### DC operation

Nominal input voltage range	12 V DC ... 24 V DC
Input voltage range	10 V DC ... 30 V DC
Input voltage range DC	10 V DC ... 30 V DC
Voltage type of supply voltage	DC
Reverse polarity protection	< yes60 V
Nominal input current ( $I_N$ )	2x 10 A (-25 °C ... 55 °C) 1x 20 A (-25 °C ... 55 °C)
Maximum current $I_{max}$	2x 15 A (-25°C ... 40°C) 1x 30 A (-25°C ... 40°C)
Transient surge protection	Varistor
Voltage drop, input/output	0.5 V

### Output data

Efficiency	> 97 %
Output voltage	$U_{in}$ -
Setting range of the output voltage ( $U_{Set}$ )	12 V DC ... 24 V DC
Nominal output current ( $I_N$ )	20 A (Increasing power) 10 A (Redundancy)
Derating	55 °C ... 70 °C (2.5%/K)
Power loss nominal load max.	7 W ( $I_{OUT} = 10$ A)
Connection in series	No

#### Signal: Floating redundancy OK

Output description	Contact closed when $U_{IN1}$ & $U_{IN2} > 8$ V
Maximum switching voltage	max. 60 V DC
Maximum inrush current	≤ 100 mA (short-circuit-proof)

### Connection data

#### Input

Connection method	Screw connection
Conductor cross section solid min.	0.2 mm <sup>2</sup>
Conductor cross section solid max.	2.5 mm <sup>2</sup>
Conductor cross section flexible min.	0.2 mm <sup>2</sup>
Conductor cross section flexible max.	2.5 mm <sup>2</sup>
Conductor cross section AWG min.	24
Conductor cross section AWG max.	14
Stripping length	9 mm
Screw thread	M2,5
Tightening torque, min	0.4 Nm

# Redundancy module - TRIO-DIODE/12-24DC/2X10/1X20



2866514

<https://www.phoenixcontact.com/pc/products/2866514>

Tightening torque max	0.5 Nm
-----------------------	--------

## Output

Connection method	Screw connection
Conductor cross section solid min.	0.5 mm <sup>2</sup>
Conductor cross section solid max.	6 mm <sup>2</sup>
Conductor cross section flexible min.	0.5 mm <sup>2</sup>
Conductor cross section flexible max.	4 mm <sup>2</sup>
Conductor cross section AWG min.	20
Conductor cross section AWG max.	10
Stripping length	14 mm
Screw thread	M3
Tightening torque, min	0.5 Nm
Tightening torque max	0.6 Nm

## Signal

Conductor cross section solid min.	0.2 mm <sup>2</sup>
Conductor cross section solid max.	2.5 mm <sup>2</sup>
Conductor cross section flexible min.	0.2 mm <sup>2</sup>
Conductor cross section flexible max.	2.5 mm <sup>2</sup>
Conductor cross section AWG min.	24
Conductor cross section AWG max.	14
Screw thread	M2,5
Tightening torque, min	0.4 Nm
Tightening torque max	0.5 Nm

## LED signaling

Types of signaling	LED
	Relay contact

Signal output: Floating redundancy OK

Status display	LED redundancy OK
Note on status display	$U_{IN1} \& U_{IN2} > 8 \text{ V}$ : LED lights up green

## Electrical properties

Insulation voltage input, output / housing	500 V
--	-------

## Product properties

Product type	Redundancy module
Product family	TRIO DIODE
MTBF (IEC 61709, SN 29500)	> 10000000 h (40 °C)

## Insulation characteristics

Protection class	III
Degree of pollution	2

# Redundancy module - TRIO-DIODE/12-24DC/2X10/1X20



2866514

<https://www.phoenixcontact.com/pc/products/2866514>

## Dimensions

Width	32 mm
Height	130 mm
Depth	115 mm
Horizontal pitch	1.8 Div.

### Installation dimensions

Installation distance right/left	0 mm / 0 mm
Installation distance top/bottom	50 mm / 50 mm

## Mounting

Mounting type	DIN rail mounting
Assembly instructions	alignable: horizontally 0 mm, vertically 50 mm
Mounting position	horizontal DIN rail NS 35, EN 60715

## Material specifications

Housing material	Metal
Type of housing	Steel sheet, zinc-plated
Side element version	Aluminum
Housing material	Steel sheet, zinc-plated

## Environmental and real-life conditions

### Ambient conditions

Degree of protection	IP20
Ambient temperature (operation)	-25 °C ... 70 °C (> 55° C derating : 2.5%/K)
Ambient temperature (storage/transport)	-40 °C ... 85 °C
Climatic class	3K3 (in acc. with EN 60721)
Max. permissible relative humidity (operation)	≤ 95 % (at 25 °C, non-condensing)
Shock	15g in all directions in acc. with IEC 60068-2-27
Vibration (operation)	< 15 Hz, amplitude ±2.5 mm 15 Hz ... 150 Hz, 2.3g t <sub>v</sub> = 90 min.

## Standards and regulations

Standard – Electronic equipment for use in electrical power installations and their assembly into electrical power installations	EN 50178/VDE 0160 (PELV)
Standard - Electrical safety	EN 60950-1/VDE 0805 (SELV)
Standard – Protection against shock currents, basic requirements for protective separation in electrical equipment	EN 50178
Standard – Safety extra-low voltage	IEC 60950-1 (SELV) and EN 60204-1 (PELV)
Standard - Safe isolation	DIN VDE 0100-410

## Approval data

UL approvals	UL/C-UL listed UL 508 UL/C-UL Recognized UL 60950-1
--------------	--

# Redundancy module - TRIO-DIODE/12-24DC/2X10/1X20



2866514

<https://www.phoenixcontact.com/pc/products/2866514>

## EMC data

Low Voltage Directive	Conformance with Low Voltage Directive 2014/35/EC
Electromagnetic compatibility	Conformance with EMC Directive 2014/30/EU
EMC requirements for noise emission	EN 61000-6-3
	EN 61000-6-4
EMC requirements for noise immunity	EN 61000-6-1
	EN 61000-6-2

### Electrostatic discharge

Standards/regulations	EN 61000-4-2
Housing	Level 3

### Electrostatic discharge

Contact discharge	6 kV (Contact discharge)
Discharge in air	8 kV (Air discharge)
Comments	Criterion B

### Electromagnetic HF field

Standards/regulations	EN 61000-4-3
-----------------------	--------------

### Electromagnetic HF field

Frequency range	80 MHz ... 3 GHz
Test field strength	10 V/m
Comments	Criterion A

### Fast transients (burst)

Standards/regulations	EN 61000-4-4
-----------------------	--------------

### Fast transients (burst)

Input	2 kV (level 3 - asymmetrical: conductor to ground)
Output	2 kV (level 3 - asymmetrical: conductor to ground)
Comments	Criterion B

### Surge voltage load (surge)

Standards/regulations	EN 61000-4-5
-----------------------	--------------

### Conducted interference

Standards/regulations	EN 61000-4-6
-----------------------	--------------

### Conducted interference

Input/Output	Level 3
Frequency range	150 kHz ... 80 MHz
Comments	Criterion A
Voltage	10 V

### Emitted interference

Standards/regulations	EN 61000-6-3
-----------------------	--------------

# Redundancy module - TRIO-DIODE/12-24DC/2X10/1X20



2866514

<https://www.phoenixcontact.com/pc/products/2866514>

Radio interference voltage in acc. with EN 55011	EN 55011 (EN 55022) Class B, area of application: Industry and residential
Emitted radio interference in acc. with EN 55011	EN 55011 (EN 55022) Class B, area of application: Industry and residential

# Redundancy module - TRIO-DIODE/12-24DC/2X10/1X20



2866514

<https://www.phoenixcontact.com/pc/products/2866514>

## Drawings

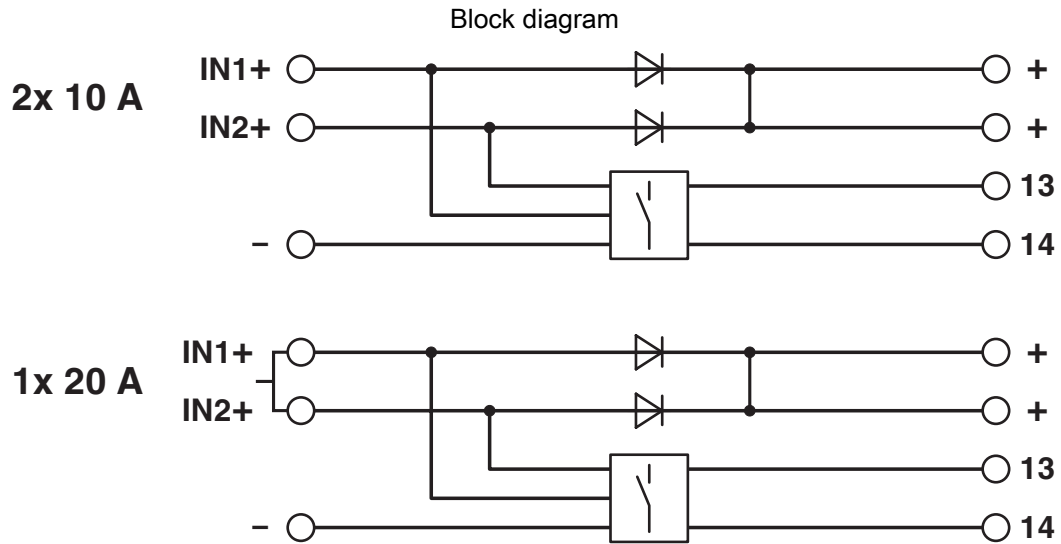

# Redundancy module - TRIO-DIODE/12-24DC/2X10/1X20



2866514

<https://www.phoenixcontact.com/pc/products/2866514>

## Approvals



**cUL Recognized**  
Approval ID: FILE E 211944



**UL Recognized**  
Approval ID: FILE E 211944



**EAC**  
Approval ID: EAC-Zulassung



**LR**  
Approval ID: 14-20005

	Nominal Voltage $U_N$	Nominal Current $I_N$	Cross Section AWG	Cross Section $\text{mm}^2$
	500 V	41 A	-	- 6



**NK**  
Approval ID: TA19447M

	Nominal Voltage $U_N$	Nominal Current $I_N$	Cross Section AWG	Cross Section $\text{mm}^2$
	500 V	63 A	-	- 10



**EAC**  
Approval ID: RU S-DE.BL08.W.00764



**UL Listed**  
Approval ID: FILE E 123528



**cUL Listed**  
Approval ID: FILE E 123528



**RINA**  
Approval ID: ELE266118XG

**ABS**

Approval ID: 20-2022537-PDA

**DNV**



# Redundancy module - TRIO-DIODE/12- 24DC/2X10/1X20



2866514

<https://www.phoenixcontact.com/pc/products/2866514>

Approval ID: TAA000011F

**cULus Recognized**

**cULus Listed**

# Redundancy module - TRIO-DIODE/12-24DC/2X10/1X20



2866514

<https://www.phoenixcontact.com/pc/products/2866514>

## Classifications

### ECLASS

ECLASS-9.0	27371010
ECLASS-10.0.1	27371010
ECLASS-11.0	27371010

### ETIM

ETIM 8.0	EC000683
----------	----------

### UNSPSC

UNSPSC 21.0	32151500
-------------	----------

# Redundancy module - TRIO-DIODE/12-24DC/2X10/1X20



2866514

<https://www.phoenixcontact.com/pc/products/2866514>

## Environmental Product Compliance

REACH SVHC	Lead 7439-92-1
China RoHS	Environmentally Friendly Use Period = 25; For information on hazardous substances, refer to the manufacturer's declaration available under "Downloads"

Phoenix Contact 2023 © - all rights reserved  
<https://www.phoenixcontact.com>

PHOENIX CONTACT GmbH & Co. KG  
Flachsmarktstraße 8  
D-32825 Blomberg  
+49 (0) 5235-3 00  
[info@phoenixcontact.com](mailto:info@phoenixcontact.com)