

Power supply, with protective coating - QUINT-PS/3AC/24DC/20/CO



2320924

<https://www.phoenixcontact.com/pc/products/2320924>

Please be informed that the data shown in this PDF document is generated from our Online Catalog. Please find the complete data in the user documentation. Our General Terms of Use for Downloads are valid.



Primary-switched power supply unit QUINT POWER, Screw connection, SFB Technology (Selective Fuse Breaking), input: 3-phase, output: 24 V DC / 20 A

Product Description

QUINT POWER power supplies with maximum functionality

QUINT POWER circuit breakers magnetically and therefore quickly trip at six times the nominal current, for selective and therefore cost-effective system protection. In addition, the high system availability is ensured by preventive function monitoring which reports critical operating states before errors can occur.

Reliable starting of heavy loads takes place via the static power reserve POWER BOOST. Thanks to the adjustable voltage, all ranges between 18 V DC ... 29.5 V DC are covered.

Your advantages

- For superior system availability
- Reliable starting of difficult loads with the static POWER BOOST power reserve with up to 1.5 times the nominal current permanently
- Fast tripping of standard circuit breakers with dynamic power reserve SFB (selective fuse breaking) technology with up to 6 times the nominal current for 12 ms
- Preventive function monitoring
- Optimum protection with dip coating for 100 % humidity

Commercial Data

Item number	2320924
Packing unit	1 pc
Minimum order quantity	1 pc
Product Key	CMPQ33
Catalog Page	Page 247 (C-4-2019)
GTIN	4046356605601
Weight per Piece (including packing)	1,834.5 g
Weight per Piece (excluding packing)	1,834 g
Customs tariff number	85044083
Country of origin	TH

Power supply, with protective coating - QUINT-PS/3AC/24DC/20/CO



2320924

<https://www.phoenixcontact.com/pc/products/2320924>

Technical Data

Input data

AC operation

Nominal input voltage range	3x 400 V AC ... 500 V AC
Input voltage range	3x 320 V AC ... 575 V AC
	2x 360 V AC ... 575 V AC
	450 V DC ... 800 V DC
Voltage type of supply voltage	AC/DC
Inrush current	< 20 A (typical)
Inrush current integral (I^2t)	< 3.2 A ² s
AC frequency range	45 Hz ... 65 Hz
Frequency range DC	0 Hz
Mains buffering time	typ. 28 ms (400 V AC)
	typ. 43 ms (500 V AC)
Current consumption	3x 1.6 A (400 V AC)
	3x 1.3 A (500 V AC)
	0.9 A (600 V DC)
Nominal power consumption	783 VA
Protective circuit	Transient surge protection; Varistor, gas-filled surge arrester
Typical response time	< 0.16 s
Permissible backup fuse	B6 B10 B16
Permissible DC backup fuse	DC: Connect a suitable fuse upstream
Recommended breaker for input protection	6 A ... 16 A (AC: Characteristics B, C, D, K)
Discharge current to PE	< 3.5 mA

Output data

Efficiency	> 93 % (at 400 V AC and nominal values)
Nominal output voltage	24 V DC \pm 1 %
Setting range of the output voltage (U_{Set})	18 V DC ... 29.5 V DC (> 24 V DC, constant capacity restricted)
Nominal output current (I_N)	20 A (-25 °C ... 60 °C, U_{OUT} = 24 V DC)
POWER BOOST (I_{Boost})	26 A (-25 °C ... 40 °C permanent, U_{OUT} = 24 V DC)
Selective Fuse Breaking (I_{SFB})	120 A (12 ms)
Magnetic circuit breaker tripping	B2 / B4 / B6 / B10 / B16 / C2 / C4 / C6
Derating	60 °C ... 70 °C (2.5%/K)
Feedback voltage resistance	max. 32 V DC
Protection against overvoltage at the output (OVP)	< 32 V DC
Control deviation	< 1 % (change in load, static 10 % ... 90 %)
	< 3 % (change in load, dynamic 10 % ... 90 %)
	< 0.1 % (change in input voltage \pm 10 %)
Residual ripple	< 40 mV _{PP} (with nominal values)

Power supply, with protective coating - QUINT-PS/3AC/24DC/20/CO



2320924

<https://www.phoenixcontact.com/pc/products/2320924>

Output power	480 W
Peak switching voltages nominal load	< 40 mV _{PP} (at nominal values, 20 MHz)
Maximum no-load power dissipation	11 W
Power loss nominal load max.	40 W
Rise time	< 0.05 s (U _{OUT} (10 % ... 90 %))
Connection in parallel	yes, for redundancy and increased capacity
Connection in series	yes

Signal: DC OK active

Output description	U _{OUT} > 0.9 x U _N : High signal
Switching voltage range	18 V ... 24 V
Output voltage	+ 24 V DC
Maximum inrush current	≤ 20 mA (short-circuit-proof)
Continuous load current	≤ 20 mA

Signal: DC OK floating

Output description	Relay contact, U _{OUT} > 0.9 x U _N : Contact closed
Maximum switching voltage	30 V AC/DC 24 V DC
Maximum inrush current	0.5 A 1 A
Continuous load current	≤ 1 A

Signal: POWER BOOST, active

Output description	I _{OUT} < I _N : High signal
Switching voltage range	18 V ... 24 V
Output voltage	+ 24 V DC
Maximum inrush current	≤ 20 mA (short-circuit-proof)
Continuous load current	≤ 20 mA

Connection data

Input

Connection method	Screw connection
Conductor cross section solid min.	0.2 mm ²
Conductor cross section solid max.	6 mm ²
Conductor cross section flexible min.	0.2 mm ²
Conductor cross section flexible max.	4 mm ²
Conductor cross section AWG min.	18
Conductor cross section AWG max.	10
Stripping length	7 mm
Screw thread	M4
Tightening torque, min	0.5 Nm
Tightening torque max	0.6 Nm

Power supply, with protective coating - QUINT-PS/3AC/24DC/20/CO



2320924

<https://www.phoenixcontact.com/pc/products/2320924>

Output

Connection method	Screw connection
Conductor cross section solid min.	0.2 mm ²
Conductor cross section solid max.	6 mm ²
Conductor cross section flexible min.	0.2 mm ²
Conductor cross section flexible max.	4 mm ²
Conductor cross section AWG min.	12
Conductor cross section AWG max.	10
Stripping length	7 mm
Screw thread	M4
Tightening torque, min	0.5 Nm
Tightening torque max	0.6 Nm

Signal

Conductor cross section solid min.	0.2 mm ²
Conductor cross section solid max.	6 mm ²
Conductor cross section flexible min.	0.2 mm ²
Conductor cross section flexible max.	4 mm ²
Conductor cross section AWG min.	18
Conductor cross section AWG max.	10
Screw thread	M4
Tightening torque, min	0.5 Nm
Tightening torque max	0.6 Nm

LED signaling

Types of signaling	LED
	Active switching output
	Relay contact

Signal output: DC OK active

Status display	$U_{OUT} > 0.9 \times U_N$: "DC OK" LED green
Note on status display	$U_{OUT} < 0.9 \times U_N$: Flashing "DC OK" LED
Color	green
Note on status display	LED flashing
	$U_{OUT} < 0.9 \times U_N$

Signal output: DC OK floating

Status display	$U_{OUT} > 0.9 \times U_N$: "DC OK" LED green
Note on status display	$U_{OUT} < 0.9 \times U_N$: Flashing "DC OK" LED
Color	green
Note on status display	LED flashing
	$U_{OUT} < 0.9 \times U_N$

Signal output: POWER BOOST, active

Power supply, with protective coating - QUINT-PS/3AC/24DC/20/CO



2320924

<https://www.phoenixcontact.com/pc/products/2320924>

Status display	$I_{OUT} > I_N$: LED "BOOST" yellow
Color	yellow

Electrical properties

Number of phases	3.00
Insulation voltage input/output	4 kV AC (type test)
	2 kV AC (routine test)
Insulation voltage output / PE	500 V DC (routine test)
Insulation voltage input / PE	3.5 kV AC (type test)
	2 kV AC (routine test)

Product properties

Product type	Power supply
Product family	QUINT POWER
MTBF (IEC 61709, SN 29500)	> 900000 h (25 °C)
	> 534000 h (40 °C)

Insulation characteristics

Protection class	I
Degree of pollution	2

Dimensions

Width	69 mm
Height	130 mm
Depth	125 mm

Installation dimensions

Installation distance right/left	5 mm / 5 mm
Installation distance top/bottom	50 mm / 50 mm

Alternative assembly

Width	125 mm
Height	130 mm
Depth	72 mm

Mounting

Assembly instructions	alignable: $P_N \geq 50\%$, 5 mm horizontally, 15 mm next to active components, 50 mm vertically alignable: $P_N < 50\%$, 0 mm horizontally, 40 mm vertically top, 20 mm vertically bottom
Mounting position	horizontal DIN rail NS 35, EN 60715
With protective coating	yes

Material specifications

Housing material	Metal
------------------	-------

Power supply, with protective coating - QUINT-PS/3AC/24DC/20/CO



2320924

<https://www.phoenixcontact.com/pc/products/2320924>

Type of housing	Steel sheet, zinc-plated
Housing material	Steel sheet, zinc-plated

Environmental and real-life conditions

Ambient conditions

Degree of protection	IP20
Ambient temperature (operation)	-40 °C ... 70 °C (> 60 °C Derating: 2,5 %/K)
Ambient temperature (storage/transport)	-40 °C ... 85 °C
Ambient temperature (start-up type tested)	-40 °C
Maximum altitude	5000 m
Climatic class	3K3 (in acc. with EN 60721)
Max. permissible relative humidity (operation)	100 % (at 25 °C, non-condensing)
Shock	18 ms, 30g, in each space direction (according to IEC 60068-2-27)
Vibration (operation)	< 15 Hz, amplitude ± 2.5 mm (according to IEC 60068-2-6) 15 Hz ... 150 Hz, 2.3g, 90 min.

Standards and regulations

Rail applications	EN 50121-4 EN 50121-3-2
Standard – Limitation of mains harmonic currents	EN 61000-3-2
Standard - Electrical safety	IEC 61010-2-201 (SELV)
Standard - Equipment safety	BG (design tested)
Standard – Protection against shock currents, basic requirements for protective separation in electrical equipment	EN 50178
Standard – Safety extra-low voltage	IEC 61010-1 (SELV) IEC 61010-2-201 (PELV)
Standard - Safe isolation	IEC 61010-2-201
Standard - safety for equipment for measurement, control, and laboratory use	IEC 61010-1
Noxious gas test	ISA-S71.04-1985 G3 Harsh Group A
Approval - requirement of the semiconductor industry with regard to mains voltage dips	SEMI F47-0706 Compliance Certificate

Overvoltage category

EN 62477-1	III
------------	-----

Approval data

CSA	CAN/CSA-C22.2 No. 60950-1-07 CSA-C22.2 No. 107.1-01
Shipbuilding approval	DNV GL (EMC B), ABS, LR, RINA, NK, BV
UL approvals	UL/C-UL listed UL 508 UL/C-UL Recognized UL 60950-1 (3-wire + PE, star net) UL ANSI/ISA-12.12.01 Class I, Division 2, Groups A, B, C, D

Power supply, with protective coating - QUINT-PS/3AC/24DC/20/CO



2320924

<https://www.phoenixcontact.com/pc/products/2320924>

(Hazardous Location)

EMC data

Low Voltage Directive	Conformance with Low Voltage Directive 2014/35/EC
Electromagnetic compatibility	Conformance with EMC Directive 2014/30/EU
EMC requirements for noise emission	EN 61000-6-3
	EN 61000-6-4
EMC requirements for noise immunity	EN 61000-6-1
	EN 61000-6-2
Noise emission	EN 55011 (EN 55022)
Noise immunity	EN 61000-6-2

Electrostatic discharge

Standards/regulations	EN 61000-4-2
-----------------------	--------------

Electrostatic discharge

Contact discharge	8 kV (Test Level 4)
Discharge in air	15 kV (Test Level 4)
Comments	Criterion A

Electromagnetic HF field

Standards/regulations	EN 61000-4-3
-----------------------	--------------

Electromagnetic HF field

Frequency range	80 MHz ... 1 GHz
Test field strength	20 V/m (Test Level 3)
Frequency range	1 GHz ... 2 GHz
Test field strength	10 V/m (Test Level 3)
Frequency range	2 GHz ... 3 GHz
Test field strength	10 V/m (Test Level 3)
Comments	Criterion A

Fast transients (burst)

Standards/regulations	EN 61000-4-4
-----------------------	--------------

Fast transients (burst)

Input	4 kV (Test Level 4 - asymmetrical)
Output	2 kV (Test Level 3 - asymmetrical)
Signal	2 kV (Test Level 4 - asymmetrical)
Comments	Criterion B

Surge voltage load (surge)

Standards/regulations	EN 61000-4-5
Input	3 kV (Test Level 3 - symmetrical)
	6 kV (Test Level 4 - asymmetrical)
Output	1 kV (Test Level 2 - symmetrical)

Power supply, with protective coating - QUINT-PS/3AC/24DC/20/CO



2320924

<https://www.phoenixcontact.com/pc/products/2320924>

	2 kV (Test Level 3 - asymmetrical)
Signal	1 kV (Test Level 2 - asymmetrical)
Comments	Criterion A

Conducted interference

Standards/regulations	EN 61000-4-6
-----------------------	--------------

Conducted interference

I/O/S	asymmetrical
Frequency range	0.15 MHz ... 80 MHz
Comments	Criterion A
Voltage	10 V (Test Level 3)

Emitted interference

Standards/regulations	EN 61000-6-3
Radio interference voltage in acc. with EN 55011	EN 55011 (EN 55022) Class B, area of application: Industry and residential
Emitted radio interference in acc. with EN 55011	EN 55011 (EN 55022) Class B, area of application: Industry and residential

Criteria

Criterion A	Normal operating behavior within the specified limits.
Criterion B	Temporary impairment to operational behavior that is corrected by the device itself.

Power supply, with protective coating - QUINT-PS/3AC/24DC/20/CO



2320924

<https://www.phoenixcontact.com/pc/products/2320924>

Drawings

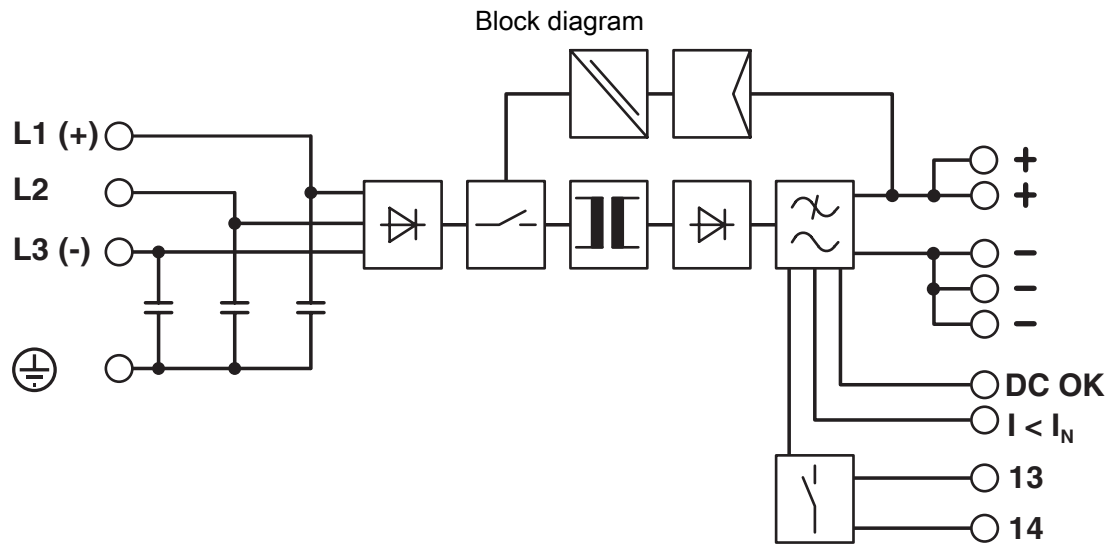

Power supply, with protective coating - QUINT-PS/3AC/24DC/20/CO



2320924

<https://www.phoenixcontact.com/pc/products/2320924>

Approvals



cUL Recognized
Approval ID: FILE E 211944



UL Recognized
Approval ID: FILE E 211944



IECEE CB Scheme
Approval ID: SI-2794



EAC
Approval ID: EAC-Zulassung



EAC
Approval ID: EAC-Zulassung



UL Listed
Approval ID: FILE E 123528



Type approved
Approval ID: SI-SIQ BG 005/002



EAC
Approval ID: RU S-DE.BL08.W.00764



UL Recognized
Approval ID: FILE E 211944



IECEE CB Scheme
Approval ID: SI-2794



cUL Recognized
Approval ID: FILE E 211944

Power supply, with protective coating - QUINT-PS/3AC/24DC/20/CO



2320924

<https://www.phoenixcontact.com/pc/products/2320924>



UL Listed

Approval ID: FILE E 123528



Type approved

Approval ID: SI-SIQ BG 005/002



EAC

Approval ID: RU S-DE.BL08.W.00764



EAC

Approval ID: RU S-DE.BL08.W.00764



EAC

Approval ID: RU S-DE.BL08.W.00764

DNV

Approval ID: TAA000030X

DNV

Approval ID: TAA000030X



cUL Listed

Approval ID: FILE E 199827



UL Listed

Approval ID: FILE E 199827



UL Listed

Approval ID: FILE E 199827



cUL Listed

Approval ID: FILE E 199827

Power supply, with protective coating - QUINT-PS/3AC/24DC/20/CO



2320924

<https://www.phoenixcontact.com/pc/products/2320924>

Classifications

ECLASS

ECLASS-9.0	27040701
ECLASS-10.0.1	27040701
ECLASS-11.0	27040701

ETIM

ETIM 8.0	EC002540
----------	----------

UNSPSC

UNSPSC 21.0	39121000
-------------	----------

Power supply, with protective coating - QUINT-PS/3AC/24DC/20/CO



2320924

<https://www.phoenixcontact.com/pc/products/2320924>

Environmental Product Compliance

REACH SVHC	Lead 7439-92-1
China RoHS	Environmentally Friendly Use Period = 25; For information on hazardous substances, refer to the manufacturer's declaration available under "Downloads"

Power supply, with protective coating - QUINT-PS/3AC/24DC/20/CO

2320924

<https://www.phoenixcontact.com/pc/products/2320924>

Accessories

DIN rail adapter

DIN rail adapter - UTA 107 - 2853983

<https://www.phoenixcontact.com/pc/products/2853983>

Universal DIN rail adapter, for screwing on switchgear



Mounting adapter

Mounting adapter - UWA 182/52 - 2938235

<https://www.phoenixcontact.com/pc/products/2938235>

Universal wall adapter for securely mounting the device in the event of strong vibrations. The device is screwed directly onto the mounting surface. The universal wall adapter is attached on the top/bottom.



Power supply, with protective coating - QUINT-PS/3AC/24DC/20/CO

2320924

<https://www.phoenixcontact.com/pc/products/2320924>

Mounting adapter

Mounting adapter - QUINT-PS-ADAPTERS7/2 - 2938206

<https://www.phoenixcontact.com/pc/products/2938206>

Assembly adapter for QUINT POWER 10A on S7-300 rail



Fan

Fan - QUINT-PS/FAN/4 - 2320076

<https://www.phoenixcontact.com/pc/products/2320076>



The fan for QUINT-PS/1AC and .../3AC can be mounted without the need for tools or other accessories. By using the fan, optimum cooling is ensured at high ambient temperatures or if the mounting position is rotated.

Power supply, with protective coating - QUINT-PS/3AC/24DC/20/CO

2320924

<https://www.phoenixcontact.com/pc/products/2320924>

Redundancy module

Redundancy module - QUINT-DIODE/12-24DC/2X20/1X40 - 2320157

<https://www.phoenixcontact.com/pc/products/2320157>



DIN rail diode module 12-24 V DC/2x20 A or 1x40 A. Uniform redundancy up to the consumer.

Redundancy module

Redundancy module - TRIO-DIODE/12-24DC/2X10/1X20 - 2866514

<https://www.phoenixcontact.com/pc/products/2866514>



Redundancy module with function monitoring, 12 ... 24 V DC, 2x 10 A, 1x 20 A

Power supply, with protective coating - QUINT-PS/3AC/24DC/20/CO

2320924

<https://www.phoenixcontact.com/pc/products/2320924>

Redundancy module, with protective coating

Redundancy module, with protective coating - QUINT-ORING/24DC/2X20/1X40 - 2320186

<https://www.phoenixcontact.com/pc/products/2320186>



Active QUINT redundancy module for DIN rail mounting with ACB (Auto Current Balancing) Technology and monitoring functions, input: 24 V DC/2x 20 A, output: 24 V DC/1 x 40 A, including mounted UTA 107/30 universal DIN rail adapter

Thermomagnetic device circuit breaker

Thermomagnetic device circuit breaker - CB TM1 1A SFB P - 2800836

<https://www.phoenixcontact.com/pc/products/2800836>



Thermomagnetic device circuit breaker, 1-pos., tripping characteristic SFB, 1 changeover contact, plug for base element.

Power supply, with protective coating - QUINT-PS/3AC/24DC/20/CO

2320924

<https://www.phoenixcontact.com/pc/products/2320924>

Thermomagnetic device circuit breaker

Thermomagnetic device circuit breaker - CB TM1 2A SFB P - 2800837

<https://www.phoenixcontact.com/pc/products/2800837>



Thermomagnetic device circuit breaker, 1-pos., tripping characteristic SFB, 1 changeover contact, plug for base element.

Thermomagnetic device circuit breaker

Thermomagnetic device circuit breaker - CB TM1 3A SFB P - 2800838

<https://www.phoenixcontact.com/pc/products/2800838>



Thermomagnetic device circuit breaker, 1-pos., tripping characteristic SFB, 1 changeover contact, plug for base element.

Power supply, with protective coating - QUINT-PS/3AC/24DC/20/CO

2320924

<https://www.phoenixcontact.com/pc/products/2320924>

Thermomagnetic device circuit breaker

Thermomagnetic device circuit breaker - CB TM1 4A SFB P - 2800839

<https://www.phoenixcontact.com/pc/products/2800839>



Thermomagnetic device circuit breaker, 1-pos., tripping characteristic SFB, 1 changeover contact, plug for base element.

Thermomagnetic device circuit breaker

Thermomagnetic device circuit breaker - CB TM1 5A SFB P - 2800840

<https://www.phoenixcontact.com/pc/products/2800840>



Thermomagnetic device circuit breaker, 1-pos., tripping characteristic SFB, 1 changeover contact, plug for base element.

Power supply, with protective coating - QUINT-PS/3AC/24DC/20/CO

2320924

<https://www.phoenixcontact.com/pc/products/2320924>

Thermomagnetic device circuit breaker

Thermomagnetic device circuit breaker - CB TM1 6A SFB P - 2800841

<https://www.phoenixcontact.com/pc/products/2800841>



Thermomagnetic device circuit breaker, 1-pos., tripping characteristic SFB, 1 changeover contact, plug for base element.

Thermomagnetic device circuit breaker

Thermomagnetic device circuit breaker - CB TM1 8A SFB P - 2800842

<https://www.phoenixcontact.com/pc/products/2800842>



Thermomagnetic device circuit breaker, 1-pos., tripping characteristic SFB, 1 changeover contact, plug for base element.

Power supply, with protective coating - QUINT-PS/3AC/24DC/20/CO

2320924

<https://www.phoenixcontact.com/pc/products/2320924>

Thermomagnetic device circuit breaker

Thermomagnetic device circuit breaker - CB TM1 10A SFB P - 2800843

<https://www.phoenixcontact.com/pc/products/2800843>



Thermomagnetic device circuit breaker, 1-pos., tripping characteristic SFB, 1 changeover contact, plug for base element.

Thermomagnetic device circuit breaker

Thermomagnetic device circuit breaker - CB TM1 12A SFB P - 2800844

<https://www.phoenixcontact.com/pc/products/2800844>



Thermomagnetic device circuit breaker, 1-pos., tripping characteristic SFB, 1 changeover contact, plug for base element.

Power supply, with protective coating - QUINT-PS/3AC/24DC/20/CO

2320924

<https://www.phoenixcontact.com/pc/products/2320924>

Thermomagnetic device circuit breaker

Thermomagnetic device circuit breaker - CB TM1 16A SFB P - 2800845

<https://www.phoenixcontact.com/pc/products/2800845>



Thermomagnetic device circuit breaker, 1-pos., tripping characteristic SFB, 1 changeover contact, plug for base element.

Type 3 surge protection device

Type 3 surge protection device - PLT-SEC-T3-3S-230-FM - 2905230

<https://www.phoenixcontact.com/pc/products/2905230>

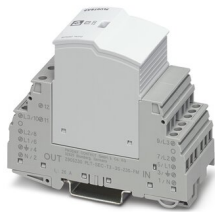

Plug-in device protection, according to type 3/class III, for 3-phase power supply networks with separate N and PE (5-conductor system: L1, L2, L3, N, PE), with integrated surge-proof fuse and remote indication contact.

Power supply, with protective coating - QUINT-PS/3AC/24DC/20/CO



2320924

<https://www.phoenixcontact.com/pc/products/2320924>

Type 3 surge protection device

Type 3 surge protection device - PLT-SEC-T3-24-FM-UT - 2907916

<https://www.phoenixcontact.com/pc/products/2907916>



Type 3 surge protection, consisting of protective plug and base element, with integrated status indicator and remote signaling for single-phase power supply networks. Nominal voltage: 24 V AC/DC

Phoenix Contact 2023 © - all rights reserved
<https://www.phoenixcontact.com>

PHOENIX CONTACT GmbH & Co. KG
Flachsmarktstraße 8
D-32825 Blomberg
+49 (0) 5235-3 00
info@phoenixcontact.com