

Power supply, with protective coating - QUINT-PS/1AC/24DC/ 5/CO



2320908

<https://www.phoenixcontact.com/pc/products/2320908>

Please be informed that the data shown in this PDF document is generated from our Online Catalog. Please find the complete data in the user documentation. Our General Terms of Use for Downloads are valid.



Primary-switched power supply unit QUINT POWER, Screw connection, DIN rail mounting, SFB Technology (Selective Fuse Breaking), input: 1-phase, output: 24 V DC / 5 A

Product Description

QUINT POWER power supplies with maximum functionality

QUINT POWER circuit breakers magnetically and therefore quickly trip at six times the nominal current, for selective and therefore cost-effective system protection. In addition, the high system availability is ensured by preventive function monitoring which reports critical operating states before errors can occur.

Reliable starting of heavy loads takes place via the static power reserve POWER BOOST. Thanks to the adjustable voltage, all ranges between 18 V DC ... 29.5 V DC are covered.

Your advantages

- For superior system availability
- Reliable starting of difficult loads with the static POWER BOOST power reserve with up to 1.5 times the nominal current permanently
- Fast tripping of standard circuit breakers with dynamic power reserve SFB (selective fuse breaking) technology with up to 6 times the nominal current for 12 ms
- Preventive function monitoring
- Optimum protection with dip coating for 100 % humidity

Commercial Data

Item number	2320908
Packing unit	1 pc
Minimum order quantity	1 pc
Product Key	CMPQ13
Catalog Page	Page 246 (C-4-2019)
GTIN	4046356520010
Weight per Piece (including packing)	1,046 g
Weight per Piece (excluding packing)	777 g
Customs tariff number	85044083
Country of origin	TH

Power supply, with protective coating - QUINT-PS/1AC/24DC/ 5/CO



2320908

<https://www.phoenixcontact.com/pc/products/2320908>

Technical Data

Input data

AC operation

Nominal input voltage range	100 V AC ... 240 V AC
	110 V DC ... 250 V DC
Input voltage range	85 V AC ... 264 V AC
	90 V DC ... 410 V DC +5 % (UL 508: ≤ 250 V DC)
Input voltage range AC	85 V AC ... 264 V AC
Input voltage range DC	90 V DC ... 410 V DC +5 % (UL 508: ≤ 250 V DC)
Electric strength, max.	300 V AC
Voltage type of supply voltage	AC/DC
Inrush current	< 15 A
Inrush current integral (I^2t)	< 1 A ² s
AC frequency range	50 Hz ... 60 Hz
Mains buffering time	typ. 55 ms (120 V AC)
	typ. 55 ms (230 V AC)
Current consumption	1.5 A (100 V AC)
	0.6 A (240 V AC)
	1.2 A (120 V AC)
	0.6 A (230 V AC)
	1.3 A (110 V DC)
	0.6 A (220 V DC)
	1.4 A (100 V DC)
	0.6 A (250 V DC)
Nominal power consumption	141 VA
Protective circuit	Transient surge protection; Varistor
Typical response time	< 0.15 s
Input fuse	5 A (slow-blow, internal)
Permissible backup fuse	B6 B10 B16 AC:
Recommended breaker for input protection	6 A ... 16 A (AC: Characteristics B, C, D, K)
Discharge current to PE	< 3.5 mA

Output data

Efficiency	typ. 90 % (230 V AC)
Nominal output voltage	24 V DC ±1 %
Setting range of the output voltage (U_{Set})	18 V DC ... 29.5 V DC (> 24 V DC, constant capacity)
Nominal output current (I_N)	5 A (-25 °C ... 60 °C, $U_{OUT} = 24$ V DC)
POWER BOOST (I_{Boost})	7.5 A (-25 °C ... 40 °C permanent, $U_{OUT} = 24$ V DC)
Selective Fuse Breaking (I_{SFB})	30 A (12 ms)
Magnetic circuit breaker tripping	B2 / B4 / C2

Power supply, with protective coating - QUINT-PS/1AC/24DC/ 5/CO



2320908

<https://www.phoenixcontact.com/pc/products/2320908>

Derating	60 °C ... 70 °C (2.5%/K)
Feedback voltage resistance	≤ 35 V DC
Protection against overvoltage at the output (OVP)	≤ 32 V DC
Control deviation	< 1 % (change in load, static 10 % ... 90 %)
	< 2 % (change in load, dynamic 10 % ... 90 %)
	< 0.1 % (change in input voltage ±10 %)
Residual ripple	< 40 mV _{PP} (with nominal values)
Output power	120 W
Maximum no-load power dissipation	3 W
Power loss nominal load max.	15 W
Rise time	< 0.1 s (U _{OUT} (10 % ... 90 %))
Connection in parallel	yes, for redundancy and increased capacity
Connection in series	yes

Signal: DC OK active

Output description	U _{OUT} > 0.9 x U _N : High signal
Switching voltage range	18 V DC ... 24 V DC
Maximum inrush current	20 mA (short-circuit-proof)
Continuous load current	≤ 20 mA

Signal: DC OK floating

Output description	Relay contact, U _{OUT} > 0.9 x U _N : Contact closed
Maximum switching voltage	30 V AC
	24 V DC
Maximum inrush current	0.5 A (ATEX/IECEX: Ohmic loads only)
	1 A (ATEX/IECEX: Ohmic loads only)
Continuous load current	1 A

Signal: POWER BOOST, active

Output description	I _{OUT} < I _N : High signal
Switching voltage range	18 V DC ... 24 V DC
Output voltage	+ 24 V DC
Maximum inrush current	20 mA (short-circuit-proof)
Continuous load current	≤ 20 mA

Connection data

Input

Connection method	Screw connection
Conductor cross section solid min.	0.2 mm ²
Conductor cross section solid max.	2.5 mm ²
Conductor cross section flexible min.	0.2 mm ²
Conductor cross section flexible max.	2.5 mm ²
Conductor cross section AWG min.	20

Power supply, with protective coating - QUINT-PS/1AC/24DC/ 5/CO



2320908

<https://www.phoenixcontact.com/pc/products/2320908>

Conductor cross section AWG max.	12
Stripping length	7 mm
Screw thread	M3
Tightening torque, min	0.5 Nm
Tightening torque max	0.6 Nm

Output

Connection method	Screw connection
Conductor cross section solid min.	0.2 mm ²
Conductor cross section solid max.	2.5 mm ²
Conductor cross section flexible min.	0.2 mm ²
Conductor cross section flexible max.	2.5 mm ²
Conductor cross section AWG min.	20
Conductor cross section AWG max.	12
Stripping length	7 mm
Screw thread	M3
Tightening torque, min	0.5 Nm
Tightening torque max	0.6 Nm

Signal

Conductor cross section solid min.	0.2 mm ²
Conductor cross section solid max.	2.5 mm ²
Conductor cross section flexible min.	0.2 mm ²
Conductor cross section flexible max.	2.5 mm ²
Conductor cross section AWG min.	20
Conductor cross section AWG max.	12
Screw thread	M3
Tightening torque, min	0.5 Nm
Tightening torque max	0.6 Nm

LED signaling

Types of signaling	LED
	Active switching output
	Relay contact

Signal output: DC OK active

Status display	$U_{OUT} > 0.9 \times U_N$: "DC OK" LED green
Note on status display	$U_{OUT} < 0.9 \times U_N$: Flashing "DC OK" LED
	$I_{OUT} < I_N$: LED ON
Color	green
Note on status display	LED flashing
	$U_{OUT} < 0.9 \times U_N$
	$I_{OUT} < I_N$

Power supply, with protective coating - QUINT-PS/1AC/24DC/ 5/CO



2320908

<https://www.phoenixcontact.com/pc/products/2320908>

Signal output: DC OK floating

Status display	$U_{OUT} > 0.9 \times U_N$: "DC OK" LED green
Note on status display	$U_{OUT} < 0.9 \times U_N$: Flashing "DC OK" LED
Color	green
Note on status display	LED flashing
	$U_{OUT} < 0.9 \times U_N$

Signal output: POWER BOOST, active

Status display	$I_{OUT} > I_N$: LED "BOOST" yellow
Color	yellow

Electrical properties

Number of phases	1.00
Insulation voltage input/output	4 kV AC (type test) 2 kV AC (routine test)
Insulation voltage output / PE	500 V DC (routine test)
Insulation voltage input / PE	3.5 kV AC (type test) 2 kV AC (routine test)

Product properties

Product type	Power supply
Product family	QUINT POWER
MTBF (IEC 61709, SN 29500)	> 1134000 h (25 °C) > 635000 h (40 °C)

Insulation characteristics

Protection class	I
Degree of pollution	2

Dimensions

Width	40 mm
Height	130 mm
Depth	125 mm

Installation dimensions

Installation distance right/left	5 mm / 5 mm
Installation distance top/bottom	50 mm / 50 mm

Alternative assembly

Width	122 mm
Height	130 mm
Depth	43 mm

Mounting

Power supply, with protective coating - QUINT-PS/1AC/24DC/ 5/CO



2320908

<https://www.phoenixcontact.com/pc/products/2320908>

Mounting type	DIN rail mounting
Assembly instructions	alignable: $P_N \geq 50\%$, 5 mm horizontally, 15 mm next to active components, 50 mm vertically alignable: $P_N < 50\%$, 0 mm horizontally, 40 mm vertically top, 20 mm vertically bottom
Mounting position	horizontal DIN rail NS 35, EN 60715
With protective coating	yes

Material specifications

Housing material	Metal
Hood version	Galvanized sheet steel, free from chrome (VI)
Side element version	Aluminum

Environmental and real-life conditions

Ambient conditions

Degree of protection	IP20
Ambient temperature (operation)	-40 °C ... 70 °C (> 60 °C Derating: 2,5 %/K)
Ambient temperature (storage/transport)	-40 °C ... 85 °C
Maximum altitude	≤ 5000 m
Climatic class	3K3 (in acc. with EN 60721)
Max. permissible relative humidity (operation)	100 % (at 25 °C, non-condensing)
Shock	18 ms, 30g, in each space direction (according to IEC 60068-2-27)
Vibration (operation)	< 15 Hz, amplitude ±2.5 mm (according to IEC 60068-2-6) 15 Hz ... 150 Hz, 2.3g, 90 min.

Standards and regulations

Rail applications	EN 50121-4
	EN 50121-3-2
HART FSK Physical Layer Test Specification Compliance	Output voltage U_{Out} compliant
Standard – Limitation of mains harmonic currents	EN 61000-3-2
Standard - Electrical safety	IEC 61010-2-201 (SELV)
Explosive atmosphere	EN 60079-15 (Zone 2)
Standard - Equipment safety	BG (design tested)
Standard – Safety extra-low voltage	IEC 61010-1 (SELV)
	IEC 61010-2-201 (PELV)
Standard - Safe isolation	IEC 61010-2-201
Standard - safety for equipment for measurement, control, and laboratory use	IEC 61010-1
Noxious gas test	ISA-S71.04-1985 G3 Harsh Group A
Approval - requirement of the semiconductor industry with regard to mains voltage dips	SEMI F47-0706 Compliance Certificate
DeviceNet approval	DeviceNet™ Power Supply Conformance Tested

Overvoltage category

Power supply, with protective coating - QUINT-PS/1AC/24DC/ 5/CO



2320908

<https://www.phoenixcontact.com/pc/products/2320908>

EN 61010-1	II (≤ 5000 m)
EN 62477-1	III (≤ 2000 m)

Approval data

CSA	CAN/CSA-C22.2 No. 60950-1-07
	CSA-C22.2 No. 107.1-01
Shipbuilding approval	DNV GL (EMC A)
SIQ	BG (type approved)
UL approvals	UL/C-UL listed UL 508
	UL/C-UL Recognized UL 60950-1
	UL ANSI/ISA-12.12.01 Class I, Division 2, Groups A, B, C, D (Hazardous Location)
DeviceNet approval	DeviceNet™ Power Supply Conformance Tested

Conformity/Approvals

ATEX	<input type="checkbox"/> II 3 G Ex ec nC IIC T4 Gc
	TÜV 11 ATEX 555674 X
INMETRO	DNV 19 0188 X
IECEX	Ex ec nC IIC T4 Gc
	IECEX TUN 11.0002X

EMC data

Low Voltage Directive	Conformance with Low Voltage Directive 2014/35/EC
Electromagnetic compatibility	Conformance with EMC Directive 2014/30/EU
EMC requirements for noise emission	EN 61000-6-3
	EN 61000-6-4
EMC requirements for noise immunity	EN 61000-6-1
	EN 61000-6-2
Noise emission	EN 55011 (EN 55022)
Noise immunity	EN 61000-6-2

Electrostatic discharge

Standards/regulations	EN 61000-4-2
-----------------------	--------------

Electrostatic discharge

Contact discharge	8 kV (Test Level 4)
Discharge in air	15 kV (Test Level 4)
Comments	Criterion A

Electromagnetic HF field

Standards/regulations	EN 61000-4-3
-----------------------	--------------

Electromagnetic HF field

Frequency range	80 MHz ... 1 GHz
Test field strength	20 V/m (Test Level 3)

Power supply, with protective coating - QUINT-PS/1AC/24DC/ 5/CO



2320908

<https://www.phoenixcontact.com/pc/products/2320908>

Frequency range	1 GHz ... 2 GHz
Test field strength	10 V/m (Test Level 3)
Frequency range	2 GHz ... 3 GHz
Test field strength	10 V/m (Test Level 3)
Comments	Criterion A

Fast transients (burst)

Standards/regulations	EN 61000-4-4
-----------------------	--------------

Fast transients (burst)

Input	4 kV (Test Level 4 - asymmetrical)
Output	2 kV (Test Level 3 - asymmetrical)
Signal	2 kV (Test Level 4 - asymmetrical)
Comments	Criterion A

Surge voltage load (surge)

Standards/regulations	EN 61000-4-5
Input	2 kV (Test Level 3 - symmetrical)
	4 kV (Test Level 4 - asymmetrical)
Output	1 kV (Test Level 2 - symmetrical)
	2 kV (Test Level 3 - asymmetrical)
Signal	1 kV (Test Level 2 - asymmetrical)
Comments	Criterion A

Conducted interference

Standards/regulations	EN 61000-4-6
-----------------------	--------------

Conducted interference

I/O/S	asymmetrical
Frequency range	0.15 MHz ... 80 MHz
Comments	Criterion A
Voltage	10 V (Test Level 3)

Emitted interference

Standards/regulations	EN 61000-6-3
Radio interference voltage in acc. with EN 55011	EN 55011 (EN 55022) Class B, area of application: Industry and residential
Emitted radio interference in acc. with EN 55011	EN 55011 (EN 55022) Class B, area of application: Industry and residential

Criteria

Criterion A	Normal operating behavior within the specified limits.
Criterion B	Temporary impairment to operational behavior that is corrected by the device itself.

Power supply, with protective coating - QUINT-PS/1AC/24DC/ 5/CO



2320908

<https://www.phoenixcontact.com/pc/products/2320908>

Drawings

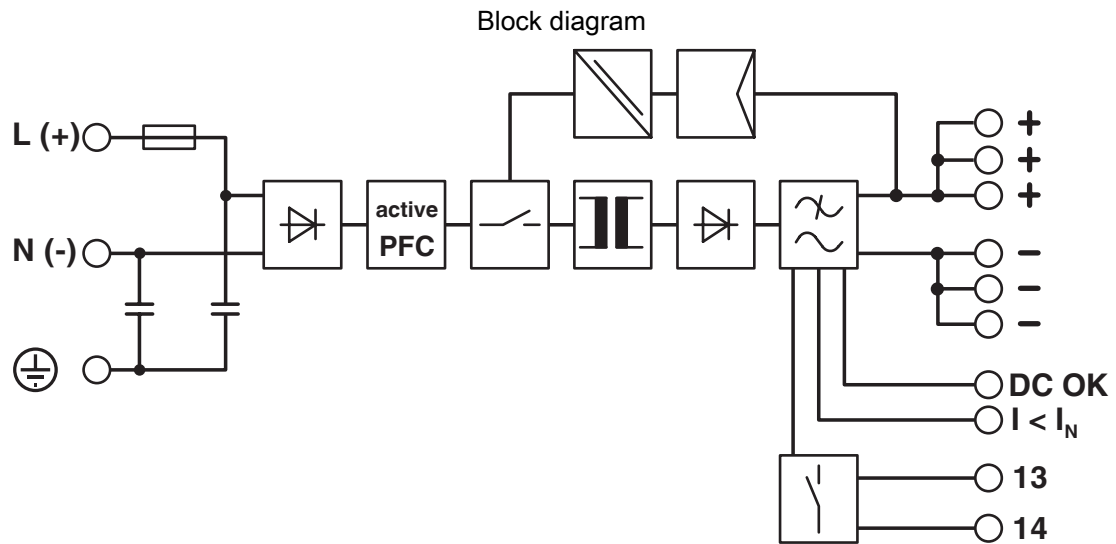

Power supply, with protective coating - QUINT-PS/1AC/24DC/ 5/CO



2320908

<https://www.phoenixcontact.com/pc/products/2320908>

Approvals



cUL Recognized
Approval ID: FILE E 211944



UL Recognized
Approval ID: FILE E 211944



IECEE CB Scheme
Approval ID: SI-6188 A1



EAC
Approval ID: EAC-Zulassung



EAC
Approval ID: RU S-DE.BL08.W.00764



UL Listed
Approval ID: FILE E 123528



Type approved
Approval ID: SI-SIQ BG 005/004

DNV

Approval ID: TAA000030X



EAC Ex
Approval ID: RU C-DE.HB49.B.00004



IECEx
Approval ID: IECEx TUN 11.0002X



NEPSI
Approval ID: GYJ20.1322X

Power supply, with protective coating - QUINT-PS/1AC/24DC/ 5/CO



2320908

<https://www.phoenixcontact.com/pc/products/2320908>



cUL Listed

Approval ID: FILE E 199827



UL Listed

Approval ID: FILE E 199827

KC-s

Approval ID: 20-KA4BO-0145X

INMETRO

Approval ID: DNV 19.0188 X



ATEX

Approval ID: TÜV 11 ATEX 555674 X

cULus Recognized

cULus Listed

Power supply, with protective coating - QUINT-PS/1AC/24DC/ 5/CO



2320908

<https://www.phoenixcontact.com/pc/products/2320908>

Classifications

ECLASS

ECLASS-9.0	27040701
ECLASS-10.0.1	27040701
ECLASS-11.0	27040701

ETIM

ETIM 8.0	EC002540
----------	----------

UNSPSC

UNSPSC 21.0	39121000
-------------	----------

Power supply, with protective coating - QUINT-PS/1AC/24DC/ 5/CO



2320908

<https://www.phoenixcontact.com/pc/products/2320908>

Environmental Product Compliance

REACH SVHC	Lead 7439-92-1
China RoHS	Environmentally Friendly Use Period = 25; For information on hazardous substances, refer to the manufacturer's declaration available under "Downloads"

Power supply, with protective coating - QUINT-PS/1AC/24DC/ 5/CO

2320908

<https://www.phoenixcontact.com/pc/products/2320908>

Accessories

Mounting adapter

Mounting adapter - UTA 107/30 - 2320089

<https://www.phoenixcontact.com/pc/products/2320089>

Universal DIN rail adapter

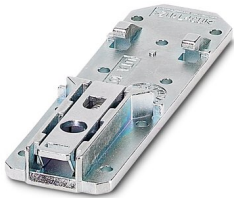

Mounting adapter

Mounting adapter - UWA 182/52 - 2938235

<https://www.phoenixcontact.com/pc/products/2938235>

Universal wall adapter for securely mounting the device in the event of strong vibrations. The device is screwed directly onto the mounting surface. The universal wall adapter is attached on the top/bottom.



Power supply, with protective coating - QUINT-PS/1AC/24DC/ 5/CO

2320908

<https://www.phoenixcontact.com/pc/products/2320908>

Mounting adapter

Mounting adapter - QUINT-PS-ADAPTERS7/1 - 2938196

<https://www.phoenixcontact.com/pc/products/2938196>

Assembly adapter for QUINT-PS... power supply on S7-300 rail



Fan

Fan - QUINT-PS/FAN/4 - 2320076

<https://www.phoenixcontact.com/pc/products/2320076>



The fan for QUINT-PS/1AC and .../3AC can be mounted without the need for tools or other accessories. By using the fan, optimum cooling is ensured at high ambient temperatures or if the mounting position is rotated.

Power supply, with protective coating - QUINT-PS/1AC/24DC/ 5/CO

2320908

<https://www.phoenixcontact.com/pc/products/2320908>

Redundancy module

Redundancy module - QUINT-DIODE/12-24DC/2X20/1X40 - 2320157

<https://www.phoenixcontact.com/pc/products/2320157>



DIN rail diode module 12-24 V DC/2x20 A or 1x40 A. Uniform redundancy up to the consumer.

Redundancy module, with protective coating

Redundancy module, with protective coating - QUINT-ORING/24DC/2X10/1X20 - 2320173

<https://www.phoenixcontact.com/pc/products/2320173>



Active QUINT redundancy module for DIN rail mounting with Auto Current Balancing ACB technology and monitoring functions, input: 24 V DC, output: 24 V DC/2 x 10 A or 1 x 20 A, including mounted UTA 107/30 universal DIN rail adapter

Power supply, with protective coating - QUINT-PS/1AC/24DC/ 5/CO

2320908

<https://www.phoenixcontact.com/pc/products/2320908>

Redundancy module

Redundancy module - TRIO-DIODE/12-24DC/2X10/1X20 - 2866514

<https://www.phoenixcontact.com/pc/products/2866514>



Redundancy module with function monitoring, 12 ... 24 V DC, 2x 10 A, 1x 20 A

Thermomagnetic device circuit breaker

Thermomagnetic device circuit breaker - CB TM1 1A SFB P - 2800836

<https://www.phoenixcontact.com/pc/products/2800836>



Thermomagnetic device circuit breaker, 1-pos., tripping characteristic SFB, 1 changeover contact, plug for base element.

Power supply, with protective coating - QUINT-PS/1AC/24DC/ 5/CO

2320908

<https://www.phoenixcontact.com/pc/products/2320908>

Thermomagnetic device circuit breaker

Thermomagnetic device circuit breaker - CB TM1 2A SFB P - 2800837

<https://www.phoenixcontact.com/pc/products/2800837>



Thermomagnetic device circuit breaker, 1-pos., tripping characteristic SFB, 1 changeover contact, plug for base element.

Type 3 surge protection device

Type 3 surge protection device - PLT-SEC-T3-230-FM-UT - 2907919

<https://www.phoenixcontact.com/pc/products/2907919>



Type 2/3 surge protection, consisting of protective plug and base element with screw connection. For single-phase power supply network with integrated status indicator and remote signaling. Nominal voltage: 230 V AC/DC

Power supply, with protective coating - QUINT-PS/1AC/24DC/ 5/CO



2320908

<https://www.phoenixcontact.com/pc/products/2320908>

Type 3 surge protection device

Type 3 surge protection device - PLT-SEC-T3-24-FM-UT - 2907916

<https://www.phoenixcontact.com/pc/products/2907916>



Type 3 surge protection, consisting of protective plug and base element, with integrated status indicator and remote signaling for single-phase power supply networks. Nominal voltage: 24 V AC/DC

Phoenix Contact 2023 © - all rights reserved
<https://www.phoenixcontact.com>

PHOENIX CONTACT GmbH & Co. KG
Flachsmarktstraße 8
D-32825 Blomberg
+49 (0) 5235-3 00
info@phoenixcontact.com