

Uninterruptible power supply - QUINT-UPS/ 24DC/ 24DC/10



2320225

<https://www.phoenixcontact.com/pc/products/2320225>

Please be informed that the data shown in this PDF document is generated from our Online Catalog. Please find the complete data in the user documentation. Our General Terms of Use for Downloads are valid.



Uninterruptible power supply with IQ technology for DIN rail mounting, input: 24 V DC, output: 24 V DC/10 A, including mounted universal DIN rail adapter UTA 107/30

Product Description

The UPS module for 24 V DC with output currents ranging from 5 to 40 A allows you to create a custom solution combining a power supply, UPS module, and energy storage.

Your advantages

- Easy handling thanks to automatic battery detection, tool-free battery replacement during operation, and communication via the IFS interface
- Optimum use of the buffer time and preventive monitoring of the energy storage
- Rapid battery charging
- Comprehensive signaling and parameterization
- Fast tripping of standard circuit breakers with SFB (selective fuse breaking) technology
- Reliable starting of difficult loads with the static POWER BOOST power reserve with up to 1.5 times the nominal current permanently

Commercial Data

Item number	2320225
Packing unit	1 pc
Minimum order quantity	1 pc
Product Key	CMUQ43
Catalog Page	Page 275 (C-4-2017)
GTIN	4046356554206
Weight per Piece (including packing)	637.7 g
Weight per Piece (excluding packing)	513 g
Customs tariff number	85371091
Country of origin	CN

Uninterruptible power supply - QUINT-UPS/ 24DC/ 24DC/10



2320225

<https://www.phoenixcontact.com/pc/products/2320225>

Technical Data

Input data

DC operation

Input voltage	24 V DC
Nominal input voltage range	24 V DC
Input voltage range	18 V DC ... 30 V DC
Input voltage range DC	18 V DC ... 30 V DC
Voltage type of supply voltage	DC
Buffer period	3 h (With battery module 38 AH)
Current consumption	19 A (maximum, mains operation)
	10.4 mA (No load, mains operation)
	4 A (Charging, mains operation)
Fixed backup threshold	≤ 22 V DC
Variable connect threshold	1 V/0.1 s

Output data

Efficiency	> 98 % (Mains operation, with charged energy storage)
	> 98 % (Battery operation)
Nominal output voltage	24 V DC
Output voltage range	18 V DC ... 30 V DC
Nominal output current (I_N)	10 A (-25 °C ... 50 °C)
Output current limit	In mains mode according to connected upstream current limiting device
	> 15 A (Battery operation)
Bridging time	10800 s
Derating	60 °C ... 70 °C (2.5%/K)
	60 °C ... 70 °C (2.5%/K)
Output power	240 W
Power dissipation	2.6 W (Mains operation)
	4.6 W (Mains operation)
	2.9 W (Battery operation)
	5.27 W (Battery operation)
Connection in parallel	yes, up to 2 modules with redundancy module
Connection in parallel	2 (Devices)
Connection in series	No
Connection in series	no

Mains operation

Nominal output voltage	24 V DC
Output voltage range	18 V DC ... 30 V DC
Nominal output current (I_N)	10 A (-25 °C ... 60 °C)
POWER BOOST (I_{Boost})	15 A (-25°C ... 40°C)

Uninterruptible power supply - QUINT-UPS/ 24DC/ 24DC/10



2320225

<https://www.phoenixcontact.com/pc/products/2320225>

Selective Fuse Breaking (I_{SFB})	60 A (-25 °C ... 60 °C)
Duration	12 ms (SFB technology)

Battery operation

Nominal output voltage	24 V DC
Output voltage range	19.2 V DC ... 27.6 V DC ($U_{OUT} = U_{BAT} - 0,5 \text{ V DC}$)
Nominal output current (I_N)	10 A (-25 °C ... 60 °C)
POWER BOOST (I_{Boost})	15 A (-25 °C ... 40 °C)
Selective Fuse Breaking (I_{SFB})	65 A (-25 °C ... 60 °C)
Duration	15 ms (SFB technology)

Signal: Alarm

Output description	Relay (floating)
Maximum switching voltage	$\leq 30 \text{ V AC/DC}$
Continuous load current	$\leq 100 \text{ mA}$

Signal: Battery charge

Output description	Relay (floating)
Maximum switching voltage	$\leq 30 \text{ V AC/DC}$
Output voltage	24 V
Continuous load current	$\leq 100 \text{ mA}$

Signal: Battery mode

Output description	Relay (floating)
Maximum switching voltage	$\leq 30 \text{ V AC/DC}$
Output voltage	24 V
Continuous load current	$\leq 100 \text{ mA}$

Energy storage

Nominal voltage U_N	24 V DC
End-of-charge voltage	24 V DC ... 29 V DC (temperature compensated)
Charging current	0.2 A ... 2.88 A
Nominal capacity range	1.3 Ah ... 140 Ah
Battery presence check/time interval	1 min.
Battery presence check (cyclic)	60 s
IQ technology	Yes
Temperature compensation	42 mV/K (preset)
Temperature compensation (preset)	42 mV/K
Network management	Yes

Connection data

Input

Connection method	Pluggable screw connection
Conductor cross section solid min.	0.2 mm ²
Conductor cross section solid max.	2.5 mm ²

Uninterruptible power supply - QUINT-UPS/ 24DC/ 24DC/10



2320225

<https://www.phoenixcontact.com/pc/products/2320225>

Conductor cross section flexible min.	0.2 mm ²
Conductor cross section flexible max.	2.5 mm ²
Conductor cross section AWG min.	16
Conductor cross section AWG max.	12
Stripping length	7 mm
Screw thread	M4
Tightening torque, min	0.5 Nm
Tightening torque max	0.6 Nm

Output

Connection method	Pluggable screw connection
Conductor cross section solid min.	0.2 mm ²
Conductor cross section solid max.	2.5 mm ²
Conductor cross section flexible min.	0.2 mm ²
Conductor cross section flexible max.	2.5 mm ²
Conductor cross section AWG min.	16
Conductor cross section AWG max.	12
Stripping length	7 mm
Screw thread	M4
Tightening torque, min	0.5 Nm
Tightening torque max	0.6 Nm

Signal

Conductor cross section solid min.	0.2 mm ²
Conductor cross section solid max.	2.5 mm ²
Conductor cross section flexible min.	0.2 mm ²
Conductor cross section flexible max.	2.5 mm ²
Conductor cross section AWG min.	24
Conductor cross section AWG max.	12
Screw thread	M4
Tightening torque, min	0.5 Nm
Tightening torque max	0.6 Nm

Interfaces

Interface	IFS (Interface system data port)
-----------	----------------------------------

LED signaling

Types of signaling	LED
	Relay contact
	Interface/software

Signal output

Signalization designation	Power In OK
Status display	LED
Note on status display	Static to

Uninterruptible power supply - QUINT-UPS/ 24DC/ 24DC/10



2320225

<https://www.phoenixcontact.com/pc/products/2320225>

	Static to
--	-----------

Signal output: Switching output

Signalization designation	Alarm
Status display	LED
Note on status display	Static to
Color	red
Note on status display	Static to

Signal output: Switching output

Signalization designation	Battery charge
Status display	LED bar graph
Note on status display	dynamic
Color	green/red
Note on status display	dynamic

Signal output: Switching output

Signalization designation	Battery mode
Status display	LED
Note on status display	Static to
Color	yellow
Note on status display	Static to

Electrical properties

Insulation voltage input/output	500 V DC
Insulation voltage input, output / housing	750 V DC

Product properties

Product type	Uninterruptible power supply
IQ technology	Yes
MTBF (IEC 61709, SN 29500)	> 500000 h (40 °C)

Insulation characteristics

Protection class	III
------------------	-----

Life expectancy (electrolytic capacitors)

Time	295585 h
------	----------

Dimensions

Width	35 mm
Height	130 mm
Depth	125 mm

Installation dimensions

Installation distance right/left	5 mm / 5 mm
Installation distance top/bottom	50 mm / 50 mm

Alternative assembly

Uninterruptible power supply - QUINT-UPS/ 24DC/ 24DC/10



2320225

<https://www.phoenixcontact.com/pc/products/2320225>

Width	123 mm
Height	130 mm
Depth	39 mm

Mounting

Mounting type	DIN rail mounting
Assembly instructions	alignable: horizontal 5 mm, vertical 50 mm
Mounting position	horizontal DIN rail NS 35, EN 60715

Material specifications

Color	aluminium
Housing material	Metal
Type of housing	Aluminum (AlMg3)
Hood version	Galvanized sheet steel, free from chrome (VI)
Housing material	Steel sheet, zinc-plated

Environmental and real-life conditions

Ambient conditions

Degree of protection	IP20
Ambient temperature (operation)	-25 °C ... 70 °C
Ambient temperature (storage/transport)	-40 °C ... 85 °C
Climatic class	3K3 (in acc. with EN 60721)
Max. permissible relative humidity (operation)	≥ 95 % (25 °C, non-condensing)
Shock	18 ms, 30g, in each space direction (according to IEC 60068-2-27)
Vibration (operation)	< 15 Hz, amplitude ±2.5 mm (according to IEC 60068-2-6) 15 Hz ... 150 Hz, 2.3g t _v = 90 min.

Standards and regulations

Rail applications	EN 50121-4
Standard – Electronic equipment for use in electrical power installations and their assembly into electrical power installations	EN 50178/VDE 0160 (PELV)
Standard - Electrical safety	EN 60950-1/VDE 0805 (SELV)

Approval data

UL approvals	UL Listed UL 508
	UL/C-UL Recognized UL 60950-1
	UL ANSI/ISA-12.12.01 Class I, Division 2, Groups A, B, C, D (Hazardous Location)

EMC data

Low Voltage Directive	Conformance with Low Voltage Directive 2014/35/EC
Electromagnetic compatibility	Conformance with EMC Directive 2014/30/EU
EMC requirements for noise emission	EN 61000-6-3
	EN 61000-6-4

Uninterruptible power supply - QUINT-UPS/ 24DC/ 24DC/10



2320225

<https://www.phoenixcontact.com/pc/products/2320225>

EMC requirements for noise immunity	EN 61000-6-1
	EN 61000-6-2
Noise immunity	EN 61000-6-2:2005

Electrostatic discharge

Standards/regulations	EN 61000-4-2
-----------------------	--------------

Electrostatic discharge

Contact discharge	8 kV (Test Level 4)
Discharge in air	15 kV (Test Level 4)
Comments	Criterion A

Electromagnetic HF field

Standards/regulations	EN 61000-4-3
-----------------------	--------------

Electromagnetic HF field

Frequency range	80 MHz ... 1 GHz
Test field strength	20 V/m
Frequency range	1 GHz ... 3 GHz
Test field strength	10 V/m
Frequency range	2 GHz ... 3 GHz
Test field strength	3 V/m
Comments	Criterion A

Fast transients (burst)

Standards/regulations	EN 61000-4-4
-----------------------	--------------

Fast transients (burst)

Input	2 kV (Test Level 3 - asymmetrical)
Output	2 kV (Test Level 3 - asymmetrical)
Signal	2 kV (Test Level 4 - asymmetrical)
Comments	Criterion A

Surge voltage load (surge)

Standards/regulations	EN 61000-4-5
Input	1 kV (Test Level 2 - symmetrical)
	2 kV (Test Level 3 - asymmetrical)
Output	1 kV (Test Level 2 - symmetrical)
	2 kV (Test Level 3 - asymmetrical)
Signal	1 kV (Test Level 2 - asymmetrical)
Comments	Criterion A

Conducted interference

Standards/regulations	EN 61000-4-6
-----------------------	--------------

Conducted interference

I/O/S	asymmetrical
Frequency range	0.15 MHz ... 80 MHz

Uninterruptible power supply - QUINT-UPS/ 24DC/ 24DC/10



2320225

<https://www.phoenixcontact.com/pc/products/2320225>

Comments	Criterion A
Voltage	10 V (Test Level 3)

Emitted interference

Standards/regulations	EN 61000-6-3
Radio interference voltage in acc. with EN 55011	EN 55011 (EN 55022) Class B, area of application: Industry and residential
Emitted radio interference in acc. with EN 55011	EN 55011 (EN 55022) Class B, area of application: Industry and residential

Criteria

Criterion A	Normal operating behavior within the specified limits.
Criterion B	Temporary impairment to operational behavior that is corrected by the device itself.

Uninterruptible power supply - QUINT-UPS/ 24DC/ 24DC/10

2320225

<https://www.phoenixcontact.com/pc/products/2320225>

Drawings

Block diagram

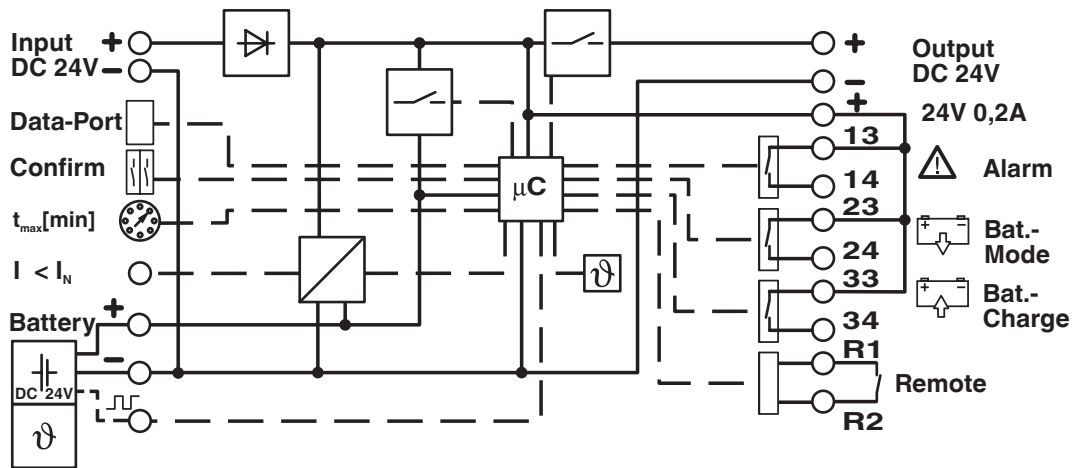

Uninterruptible power supply - QUINT-UPS/ 24DC/ 24DC/10



2320225

<https://www.phoenixcontact.com/pc/products/2320225>

Approvals



cUL Recognized
Approval ID: FILE E 211944



UL Recognized
Approval ID: FILE E 211944



EAC
Approval ID: EAC-Zulassung



LR
Approval ID: LR22136091TA



UL Recognized
Approval ID: FILE E 211944



BV
Approval ID: 41516/B0 BV



EAC
Approval ID: EAC-Zulassung



UL Listed
Approval ID: FILE E 123528



cUL Recognized
Approval ID: FILE E 211944



cUL Listed
Approval ID: FILE E 123528

ABS

Approval ID: 22-2244289-PDA



cUL Listed
Approval ID: FILE E 123528

Uninterruptible power supply - QUINT-UPS/ 24DC/ 24DC/10





2320225

<https://www.phoenixcontact.com/pc/products/2320225>

 **UL Listed**
Approval ID: FILE E 123528

ABS
Approval ID: 22-2244289-PDA

 **BV**
Approval ID: 41516/B0 BV

 **LR**
Approval ID: LR22136091TA

 **EAC**
Approval ID: RU S-DE.BL08.W.00764

 **EAC**
Approval ID: RU S-DE.BL08.W.00764

 **EAC**
Approval ID: RU-DE.B.00184/20

 **EAC**
Approval ID: RU-DE.B.00184/20

DNV
Approval ID: TAA0000265

DNV
Approval ID: TAA0000265

 **KC**
Approval ID: R-R-PCK-2320225

 **KC**
Approval ID: R-R-PCK-2320225

Uninterruptible power supply - QUINT-UPS/ 24DC/ 24DC/10



2320225

<https://www.phoenixcontact.com/pc/products/2320225>



cUL Listed

Approval ID: FILE E 199827



UL Listed

Approval ID: FILE E 199827



UL Listed

Approval ID: FILE E 199827



cUL Listed

Approval ID: FILE E 199827

Uninterruptible power supply - QUINT-UPS/ 24DC/ 24DC/10



2320225

<https://www.phoenixcontact.com/pc/products/2320225>

Classifications

ECLASS

ECLASS-9.0	27040705
ECLASS-10.0.1	27040705
ECLASS-11.0	27040705

ETIM

ETIM 8.0	EC000382
----------	----------

UNSPSC

UNSPSC 21.0	39121000
-------------	----------

Uninterruptible power supply - QUINT-UPS/ 24DC/ 24DC/10



2320225

<https://www.phoenixcontact.com/pc/products/2320225>

Environmental Product Compliance

REACH SVHC	Lead 7439-92-1
China RoHS	Environmentally Friendly Use Period = 25;
	For information on hazardous substances, refer to the manufacturer's declaration available under "Downloads"

Uninterruptible power supply - QUINT-UPS/ 24DC/ 24DC/10



2320225

<https://www.phoenixcontact.com/pc/products/2320225>

Accessories

Energy storage

Energy storage - UPS-BAT/PB/24DC/1.2AH - 1274520

<https://www.phoenixcontact.com/pc/products/1274520>



Energy storage, VRLA-AGM, 24 V DC, 1.2 Ah, automatic detection and communication with QUINT UPS-IQ

Energy storage

Energy storage - UPS-BAT/PB/24DC/4AH - 1274117

<https://www.phoenixcontact.com/pc/products/1274117>



Energy storage, VRLA-AGM, 24 V DC, 4 Ah, automatic detection and communication with QUINT UPS-IQ

Uninterruptible power supply - QUINT-UPS/ 24DC/ 24DC/10

2320225

<https://www.phoenixcontact.com/pc/products/2320225>

Energy storage

Energy storage - UPS-BAT/PB/24DC/7AH - 1274118

<https://www.phoenixcontact.com/pc/products/1274118>



Energy storage, VRLA-AGM, 24 V DC, 7 Ah, automatic detection and communication with QUINT UPS-IQ

Energy storage

Energy storage - UPS-BAT/PB/24DC/12AH - 1274119

<https://www.phoenixcontact.com/pc/products/1274119>



Energy storage, VRLA-AGM, 24 V DC, 12 Ah, automatic detection and communication with QUINT UPS-IQ

Uninterruptible power supply - QUINT-UPS/ 24DC/ 24DC/10



2320225

<https://www.phoenixcontact.com/pc/products/2320225>

Energy storage

Energy storage - UPS-BAT/VRLA/24DC/20AH - 1109004

<https://www.phoenixcontact.com/pc/products/1109004>



Energy storage, lead AGM, VRLA technology, 24 V DC, 20 Ah, automatic detection and communication with QUINT UPS-IQ

Energy storage

Energy storage - UPS-BAT/LI-ION/24DC/924WH - 2908232

<https://www.phoenixcontact.com/pc/products/2908232>



Energy storage device, LI-ION technology, 24 V DC, 924 Wh, for ambient temperatures of -25 °C ... 60 °C, automatic detection and communication with QUINT UPS-IQ

Uninterruptible power supply - QUINT-UPS/ 24DC/ 24DC/10



2320225

<https://www.phoenixcontact.com/pc/products/2320225>

Energy storage

Energy storage - UPS-BAT/VRLA/24DC/1.3AH - 2320296

<https://www.phoenixcontact.com/pc/products/2320296>



Energy storage device, lead AGM, VRLA technology, 24 V DC, 1.3 Ah, tool-free battery replacement, automatic detection, and communication with QUINT UPS-IQ

Energy storage

Energy storage - UPS-BAT/VRLA/24DC/ 3.4AH - 2320306

<https://www.phoenixcontact.com/pc/products/2320306>



Energy storage device, lead AGM, VRLA technology, 24 V DC, 3.4 Ah, tool-free battery replacement, automatic detection, and communication with QUINT UPS-IQ

Uninterruptible power supply - QUINT-UPS/ 24DC/ 24DC/10



2320225

<https://www.phoenixcontact.com/pc/products/2320225>

Energy storage

Energy storage - UPS-BAT/VRLA/24DC/7.2AH - 2320319

<https://www.phoenixcontact.com/pc/products/2320319>



Energy storage device, lead AGM, VRLA technology, 24 V DC, 7.2 Ah, tool-free battery replacement, automatic detection, and communication with QUINT UPS-IQ

Energy storage

Energy storage - UPS-BAT/VRLA/24DC/12AH - 2320322

<https://www.phoenixcontact.com/pc/products/2320322>



Please use the following item in new systems: 1274119.
Energy storage device, lead AGM, VRLA technology, 24 V DC, 12 Ah, tool-free battery replacement, automatic detection, and communication with QUINT UPS-IQ

Uninterruptible power supply - QUINT-UPS/ 24DC/ 24DC/10



2320225

<https://www.phoenixcontact.com/pc/products/2320225>

Energy storage

Energy storage - UPS-BAT/VRLA/24DC/38AH - 2320335

<https://www.phoenixcontact.com/pc/products/2320335>



Energy storage device, lead AGM, VRLA technology, 24 V DC, 38 Ah, automatic detection, and communication with QUINT UPS-IQ

Energy storage

Energy storage - UPS-BAT/VRLA-WTR/24DC/13AH - 2320416

<https://www.phoenixcontact.com/pc/products/2320416>



Energy storage device, lead AGM, VRLA technology, 24 V DC, 13 Ah, tool-free battery replacement, automatic detection, and communication with QUINT UPS-IQ

Uninterruptible power supply - QUINT-UPS/ 24DC/ 24DC/10



2320225

<https://www.phoenixcontact.com/pc/products/2320225>

Energy storage

Energy storage - UPS-BAT/VRLA-WTR/24DC/26AH - 2320429

<https://www.phoenixcontact.com/pc/products/2320429>



Energy storage device, lead AGM, VRLA technology, 24 V DC, 26 Ah, tool-free battery replacement, automatic detection, and communication with QUINT UPS-IQ

Energy storage

Energy storage - UPS-BAT/LI-ION/24DC/120WH - 2320351

<https://www.phoenixcontact.com/pc/products/2320351>



Energy storage device, LI-ION technology, 24 V DC, 120 Wh, for ambient temperatures of -20°C ... 60°C, automatic detection and communication with QUINT UPS-IQ

Uninterruptible power supply - QUINT-UPS/ 24DC/ 24DC/10



2320225

<https://www.phoenixcontact.com/pc/products/2320225>

Energy storage

Energy storage - UPS-CAP/24DC/10A/10KJ - 2320377

<https://www.phoenixcontact.com/pc/products/2320377>



Maintenance-free energy storage based on double-layer capacitor, 24 V DC, 10 kJ, automatic detection and communication with QUINT UPS-IQ

Energy storage

Energy storage - UPS-CAP/24DC/20A/20KJ - 2320380

<https://www.phoenixcontact.com/pc/products/2320380>



Maintenance-free energy storage based on double-layer capacitor, 24 V DC, 20 kJ, automatic detection and communication with QUINT UPS-IQ

Uninterruptible power supply - QUINT-UPS/ 24DC/ 24DC/10

2320225

<https://www.phoenixcontact.com/pc/products/2320225>

Mounting adapter

Mounting adapter - QUINT-PS-ADAPTERS7/1 - 2938196

<https://www.phoenixcontact.com/pc/products/2938196>

Assembly adapter for QUINT-PS... power supply on S7-300 rail



Mounting adapter

Mounting adapter - UTA 107/30 - 2320089

<https://www.phoenixcontact.com/pc/products/2320089>

Universal DIN rail adapter

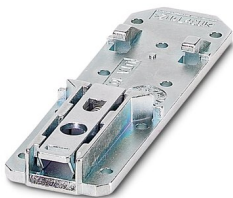

Uninterruptible power supply - QUINT-UPS/ 24DC/ 24DC/10



2320225

<https://www.phoenixcontact.com/pc/products/2320225>

Mounting adapter

Mounting adapter - UWA 182/52 - 2938235

<https://www.phoenixcontact.com/pc/products/2938235>



Universal wall adapter for securely mounting the device in the event of strong vibrations. The device is screwed directly onto the mounting surface. The universal wall adapter is attached on the top/bottom.

Data cable

Data cable - IFS-RS232-DATACABLE - 2320490

<https://www.phoenixcontact.com/pc/products/2320490>



Data cable for communication between devices with a D-SUB 9 RS-232 connection and Phoenix Contact devices with the 12-pos. IFS data port such as QUINT UPS-IQ or TRIO UPS.

Uninterruptible power supply - QUINT-UPS/ 24DC/ 24DC/10



2320225

<https://www.phoenixcontact.com/pc/products/2320225>

Data cable

Data cable - IFS-USB-DATACABLE - 2320500

<https://www.phoenixcontact.com/pc/products/2320500>

Used for communicating between industrial PCs and Phoenix Contact devices with the 12-pos. IFS data port, such as QUINT UPS or TRIO UPS.



Memory block

Memory block - IFS-CONFSTICK - 2986122

<https://www.phoenixcontact.com/pc/products/2986122>

Multi-functional memory block for the INTERFACE systemf for easy storage and backup of the configuration.



Uninterruptible power supply - QUINT-UPS/ 24DC/ 24DC/10



2320225

<https://www.phoenixcontact.com/pc/products/2320225>

Memory block

Memory block - IFS-CONFSTICK-L - 2901103

<https://www.phoenixcontact.com/pc/products/2901103>



Multi-functional memory block with handle for the INTERFACE system; for easy storage and back up of the configuration.

Phoenix Contact 2023 © - all rights reserved

<https://www.phoenixcontact.com>

PHOENIX CONTACT GmbH & Co. KG

Flachsmarktstraße 8

D-32825 Blomberg

+49 (0) 5235-3 00

info@phoenixcontact.com